

SALUS
CONTROLS

EV CHARGER



Installation Manual





SALUS EV Charger (AC)

MODEL NUMBER

EV7EU : 7kW (1-phase) socket type

EV11EU : 11kW (3-phase) socket type

EV7UK : 7kW (1-phase) socket type (UK version)

The Salus EV Charger Mode-3 AC series offers charging power from 7kW to 11kW via a Type-2 socket for your Electric Vehicles. Its slim design makes it suitable for both indoor and outdoor environments, ideal for residential use.

It connects to the Internet via WiFi and can be controlled using a smartphone app. The app provides:

- Charging monitoring and control
- Off-peak scheduling for cost-efficient charging
- Charging history for tracking and analysis
- NFC access management for authorized users
- Multi-charger management in one account

The UK model (EV7UK) includes PEN fault detection, eliminating the need for an additional earth electrode, and complies with UK EV (Smart Charge Points) Regulations.

Important Safety Information

 The installation, maintenance, & servicing of the charger **must be performed only by a qualified personnel per applicable local regulations**. The installer must ensure the installation follows local, regional and national regulations and guideline.

 When using electric products, basic precautions should always be followed

 **Turn off power at the circuit breaker** before installing or cleaning the EV charger.

 **Do not install or use the EV charger near flammable, explosive, or combustible materials, chemicals or solvents, gas pipes or steam outlets, radiators or batteries, and areas that are easily get flooded, at high humidity or with running water.** Don't spray any liquid into the charging socket or the charging connector. Never submerge the charging connector in liquid. Do not open the cover in rain.

 **Use the EV Charger only within the specified operating temperatures.** It is not recommended to install the charger in a position under direct sunlight or extreme weather conditions.

 **Do not use the EV Charger if the enclosure or connector or socket is broken, cracked, opened, or shows any indication of damage, or fails to operate.** Do not use if the charging cable is frayed, has broken insulation, or has any signs of damage or the vehicle plug or electrical outlet is dirty. Do not touch the charging cable if the connector emits smoke or begins to melt, if possible, stop charging.



Do not attempt to disassemble, repair, tamper with, or modify the EV Charger. Do not insert fingers or foreign objects into any part of the EV Charger, and do not touch its end terminals with fingers or sharp metallic objects. Sharp elements exist, beware of injurious cuts.



Do not use cleaning solvents on any part of the charger. Use a clean, dry cloth to remove dust and dirt.



This device should be supervised when used around children.



Handle with care with transporting the EV Charger, ensure that it is within storage temperature when moving, transporting, or storing. Do not subject it to strong force in any kind or step on the EV Charger to prevent damage to it or any components.



Take appropriate **precautions with electronic medical implants.**



Follow all the safety and installation instructions carefully during installation and operation for the EV charger. Incorrect installation and testing of the EV Charger could potentially damage the vehicle's battery, components, and/or the EV Charger itself. Failure to follow instructions may be a safety hazard and/or cause equipment malfunction.



The information in this manual may be changed without prior notice. It does not represent any obligation on the part of the manufacturer. Images in this manual are for illustration purposes only and might differ from the delivered product.

Electrical Protection

- The EV Charger must be permanently connected to the electrical Earth of the installation.
- Certified Circuit Breakers should be installed upstream and shall comply with standard with IEC 60898-1. The rated voltage and current of the Circuit Breakers shall be 240V 40A for the 7kW model, 400V/20A for the 11kW model and 400V/40A for the 22kW model.
- A certified Residual Current Device (RCD) should be installed upstream. RCDs shall comply with one of the following standards: IEC 61008-1 or IEC 61009-1. The RCD can be a type A 30mA RCCB or RCBO, also can be Type B RCD, in accordance with local regulations. The rated voltage and current of the RCD shall be 240V 40A for the 7kW model, 400V/20A for the 11kW model and 400V/40A for the 22kW model.
- Both an MCB and RCD (i.e. RCCB, RCBO, etc.) needs to be installed. Note: the RCD needs to be the first device upstream from the EV charger and mounted in close proximity to the charger.
- The combination of the EV Charger and the RCD (i.e. RCCB, RCBO, etc.) installed upstream can meet the requirements of OVCIII.
- The installer must select the RCD, Circuit Breaker, earthing configuration (ground earth connection is required) and any devices by following the current local regulations. Local installation guideline should also be followed to ensure the unit is installed in accordance to any local restrictions. All these protection devices shall be chosen with appropriated technical specification, such as:

Working voltage \geq charging station working voltage,
Working current \geq charging station working current,
Ingress Protection (IP) \geq IP54 or installed inside IP54 protection box
for outdoor use.

Overview

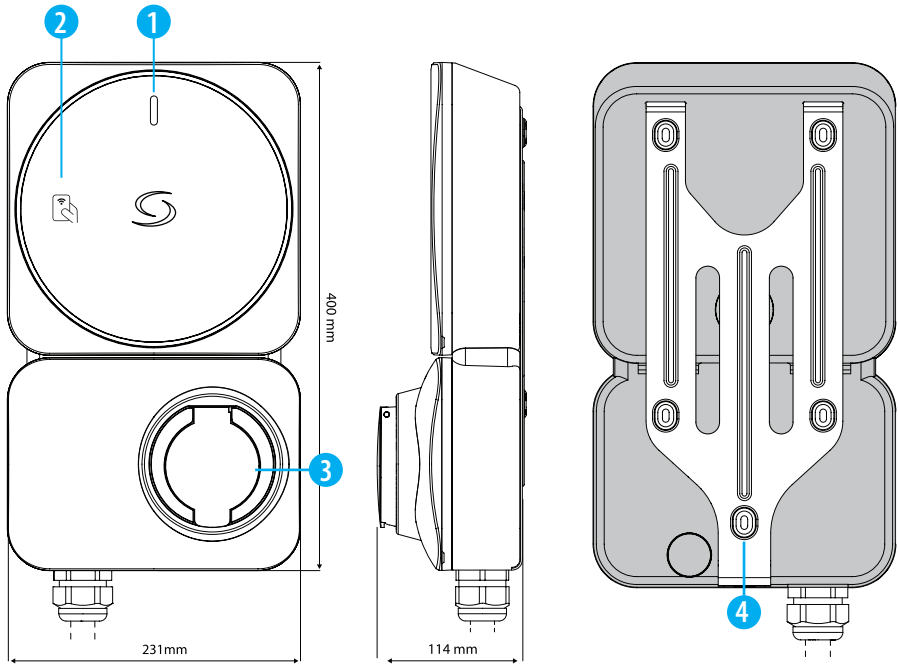

- 1. LED for charging indicator
- 2. NFC reader for authentication

- 3. Type 2 charging socket
- 4. Y-shape metallic wall mount





MODEL	NO. OF PHASES	OUTPUT CURRENT	CONNECTION	POWER
EV7EU	1 - PHASE	32A	TYPE 2 SOCKET	7kW
EV11EU	3 - PHASE	16A	TYPE 2 SOCKET	11kW

For UK only (with PEN fault protection)









EV7UK	1 - PHASE	32A	TYPE 2 SOCKET	7kW
--------------	-----------	-----	---------------	-----

LED Status

DURING SETUP

Ready to set up Wi-Fi		SLOW Blink
Connected to Wi-Fi		SLOW Blink
Connected to Cloud (or OCPP server)		Solid
No connection		FAST Blink

CHARGING OPERATION

Standby		Solid
Charger is locked		SLOW Blink
Charger is waiting for NFC		Solid
Charger is waiting for schedule		SLOW Blink
Charger is waiting for EV to start charging		SLOW Blink
Charging		Solid
Finished charging		Solid
NFC card is verified		Blink 3 times
NFC card verification failed		Blink 3 times
Error (disconnect all cable, switch off main power supply and contact technician)		Solid

Technical specifications

	SINGLE PHASE (EV7EU / EV7UK)	THREE PHASE (EV11EU)
Input voltage	230V AC 50Hz	400V AC 50Hz
Charging current & power	32A / 7kW	16A / 11kW
Charging mode	Mode 3	
Charging connector	IEC 62196 - Type 2 socket with lock	
Cable section	Up to 10mm ²	
Cable entry	Bottom and rear side	
Electrical protection	6mA DC residual current detection Anti-welding protection Over current protection Over/under voltage protection Over temperature protection Surge protection PEN fault protection (EV7UK only), without the need for additional earth rod installation.	
LED display	LED backlight for logo and multi-colour LED for charging status	
NFC reader	Mifare (13.56MHz), ISO14443-A	
Connectivity	IEEE 802.11bgn Wi-Fi (2.4GHz)	
Communication	Mobile App operation	
Firmware update	Over the air firmware update capability	
Security	Wi-Fi : WEP, WPA-TKIP, WPA2-CCMP, PMF and WPA3	
Ingress protection rating	IP54	
Impact protection rating	IK08	
Material (Enclosure)	PC UV stabilized (UL94 V-0 fire rated)	
Storage temperature	-30°C to 80°C	
Operating temperature	7kW model : -25°C to 50°C	11kW model : -25°C to 45°C
Operating humidity	Up to 95% RH (non-condensed)	
Working altitude	Up to 2,000m	
Dimensions (H x W x D)	400mm x 231mm x 114mm	
Net weight	3.7kg	
Accessory	Y-shape mount NFC card x 3 pcs	

Installation and electrical connections

1. Mount the EV charger

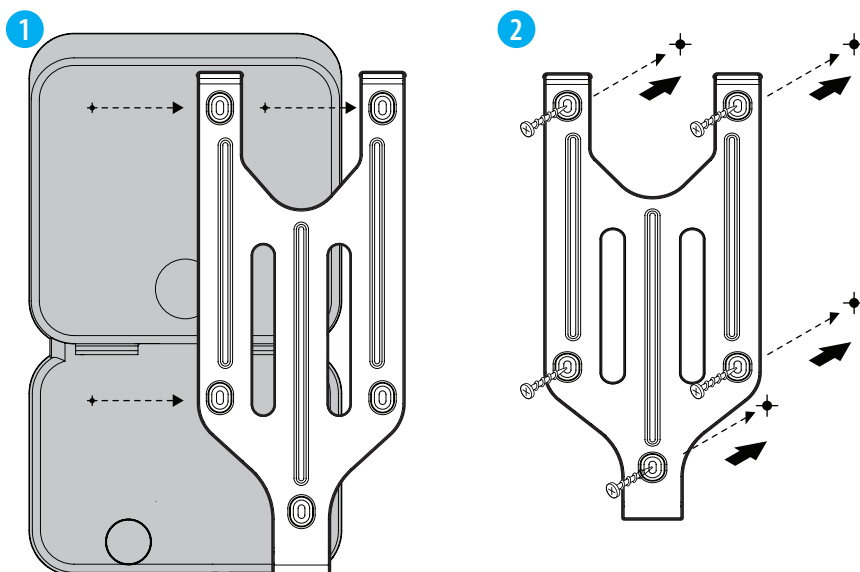

Use the screws (included) to fix the mounting plate on to the wall.

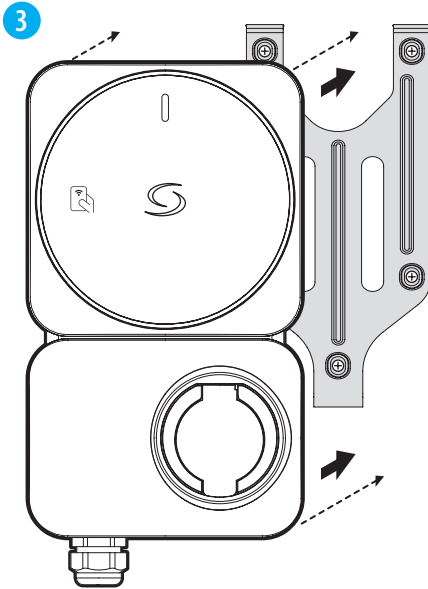

Attach the EV charger back to the mounting plate.

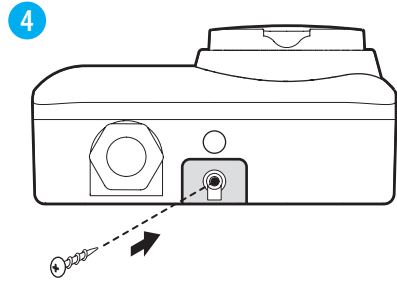

Tighten the screw at the mounting plate bottom to fix the EV charger firmly to it.

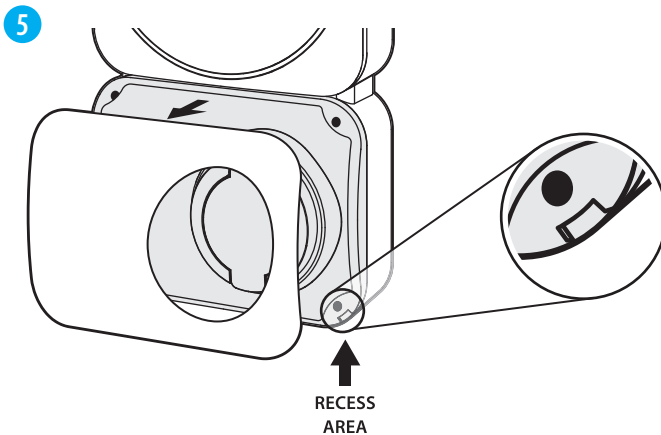

Open the deco-cover, there is a **recess area** at the corner for opening it easily.

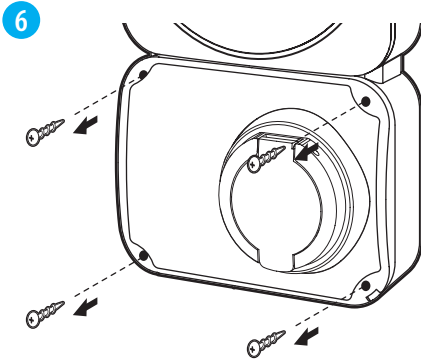

Loosen the screws at each corner of the top cover, then open it to access the internal part for wiring and set up.

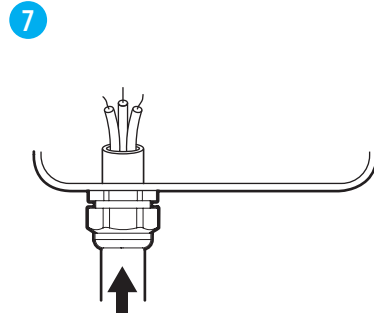

Pass the power supply cable through the cable gland supplied.

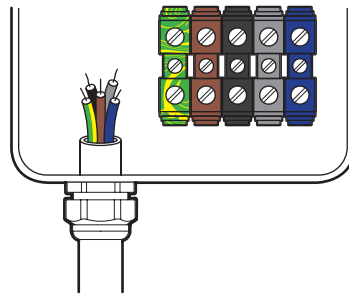
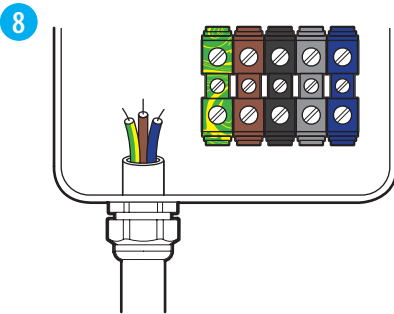

Insert the cable into the EV charger and connect it to the terminals, following the configurations listed for **single-phase** or **three-phase** power input.

Single phase:

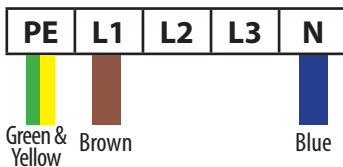

Three phase:

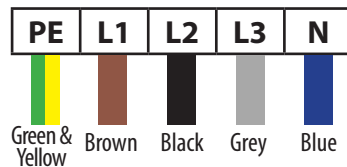

* The above colors are used following the IEC standard, some regions may use other standardized colors.

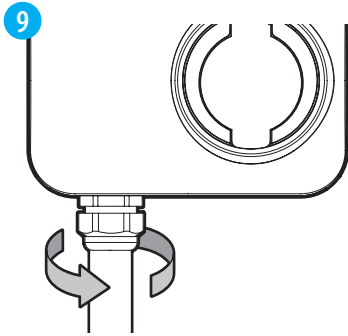

After finishing the wiring, the **cable gland** must be tightened to the EV charger in order to secure the cables.

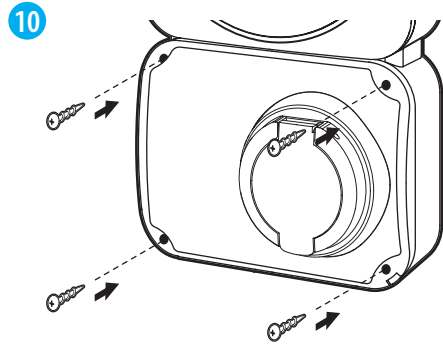

Install the top cover and tighten the screws securely.

2. Finish the installation

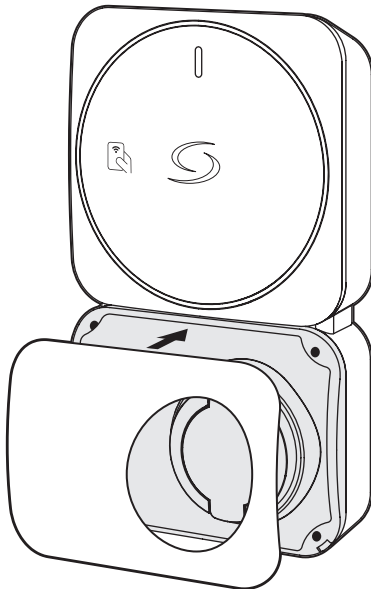

Position the deco cover over the top cover, aligning it properly.

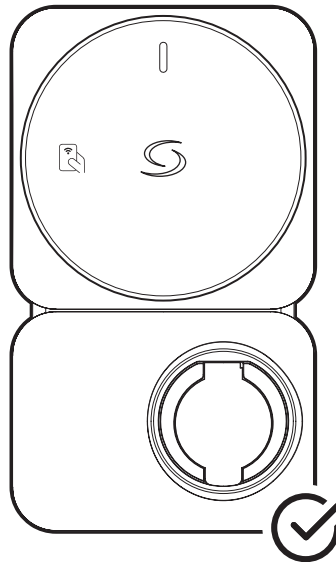

Installation is complete.

Setup

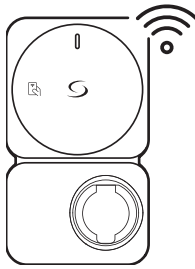

Connect your EV Charger to the Internet via Wi-Fi.

Use the smartphone app to register it to your account.

Step 1 : Set up Wi-Fi Connection to the Internet

1.1

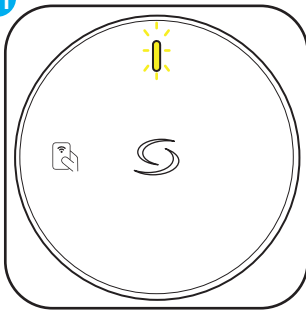

After powering ON, the EV charger will broadcast a Wi-Fi Access Point for 5 minutes. LED flashes YELLOW.

* The Wi-fi Connection setup must be finished within 5 minutes.

1.2

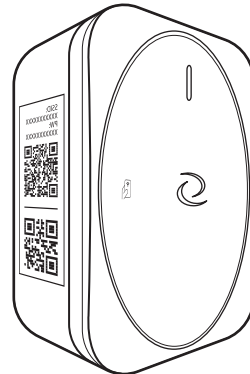

Use a mobile device in order to connect to the EV charger access point.

Scan the QR code #1 printed on the charger label to connect automatically

Or

Connect manually using the SSID and password printed on the label

1.3

Once connected, the web browser on the mobile device should open automatically and show the EV Charger Wi-Fi set up page.



Otherwise, scan the QR code above in order to access the Wi-Fi set up page.

or
Open the browser and enter 192.168.3.1 in the address bar.

1.4

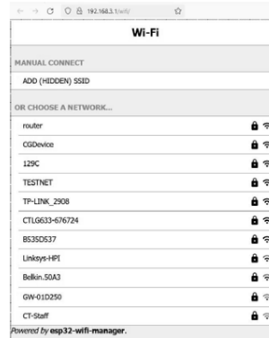

On the Wi-Fi setup page, select a network from the list and enter the password to connect the EV charger.

1.5

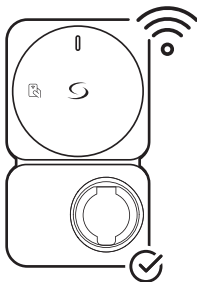

The EV charger is now connected to the Wi-Fi network.

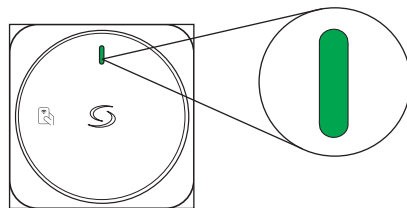

When connected, the LED will show a solid green light

Step 2: Download the smartphone App to continue the set up



Download the Salus EV charger App and register an user account. **Please note:** If you already have an Salus Premium Lite account, it will be compatible with the Salus EV Charging app as well.

Step 3 : (If needed) Create Smart EV Charger account

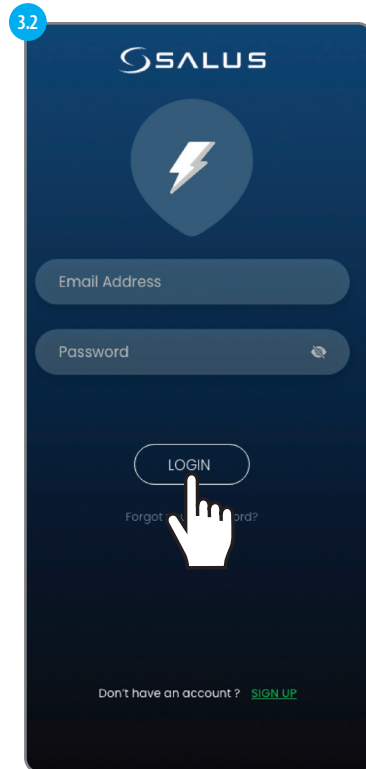
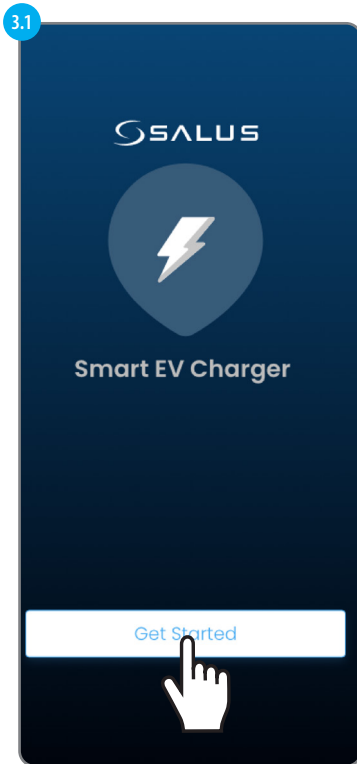

In order to create a account we must select the **SIGN UP** option.

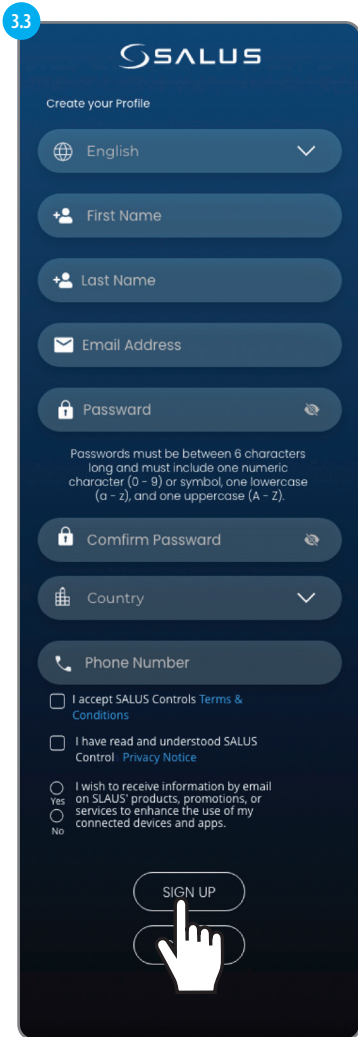

Add the the info requested in order to proceed with account creation.
Then select **SIGN UP**.

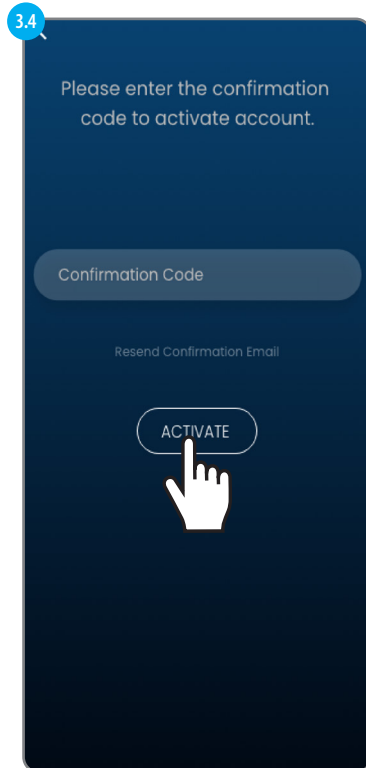

A confirmation code email will be sent via email. Add the code and then select **ACTIVATE**.

Step 4 : Adding your first EV Charger

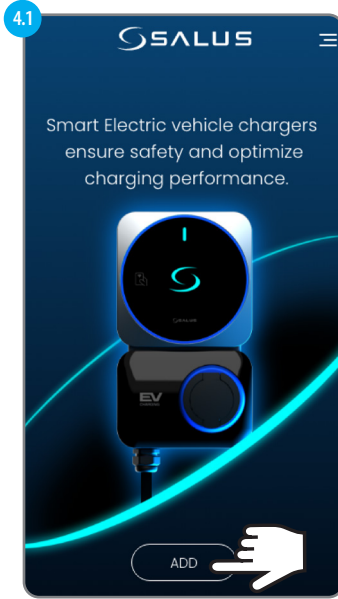

Select ADD in order to proceed with the addition of the EV Charger to the app.

The EV Charger can be added in 2 ways:

4.2 Align QR code in frame to scan

a Scan the **QR code #2** provided on the side label of the EV Charger.

b Type the serial number provided on the side label of the EV Charger.

QR code #1
Set up Wi-Fi

SSID :
XXXXXXXXXXXX
PW :
XXXXXXXXXXXX

QR code #2
Add to App

Serial number
YYYYWWSALV7SE01
V7SEXXXXXX

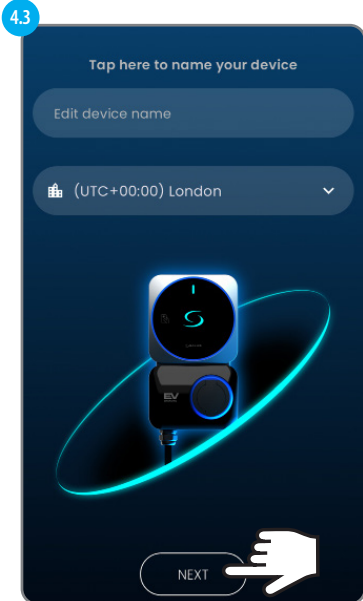

Add a name for the device & set Time Zone

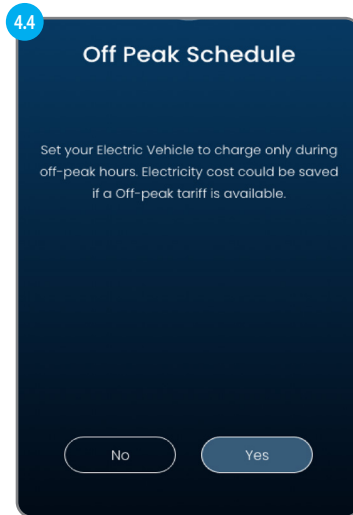

Set your choice for Off Peak Schedule

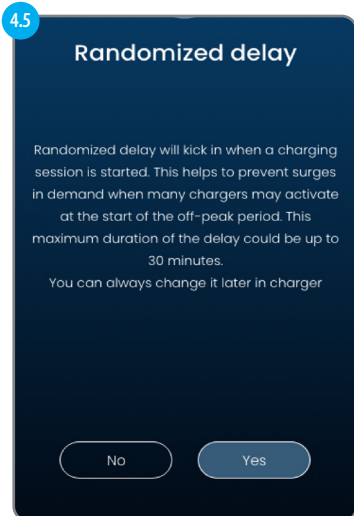

Set your choice for Randomized delay

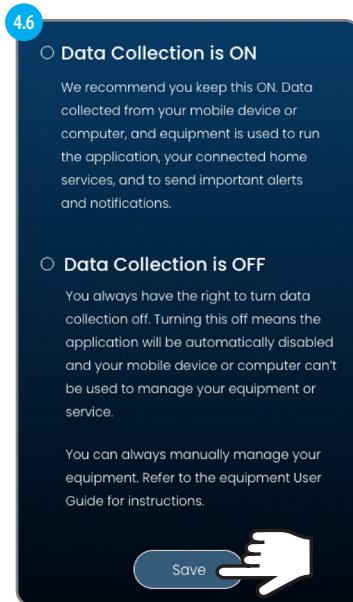

Set your choice for Data Collection and select **Save**

Step 5 : Managing multiple chargers

Multiple chargers can be associated with a single user account. This allows the user to conveniently monitor and manage all of their chargers from one place.

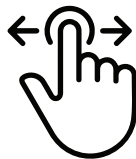

Swipe the app's dashboard to cycle through different chargers

Dashboard features and settings



Step 6 : Charging flow



Connect the charging cable to the EV and the EV charger.
Swipe NFC card on the EV charger, or select **Start** to start charging.



Wait to reach charging schedule, or select **Boost** to override schedule and charge at once.



Charging is initiated.



Charging starts.

Charging flow - potential displays



Charging screen.



This screen will appear when EV chargers stops or suspends receiving charge.

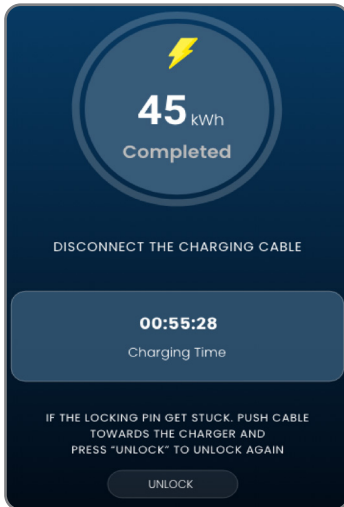

Charging completed.

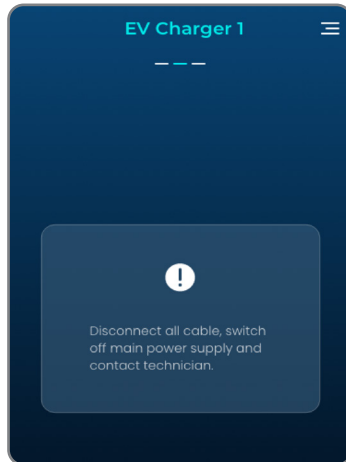

Error screen.

In-App Settings for the EV Charger

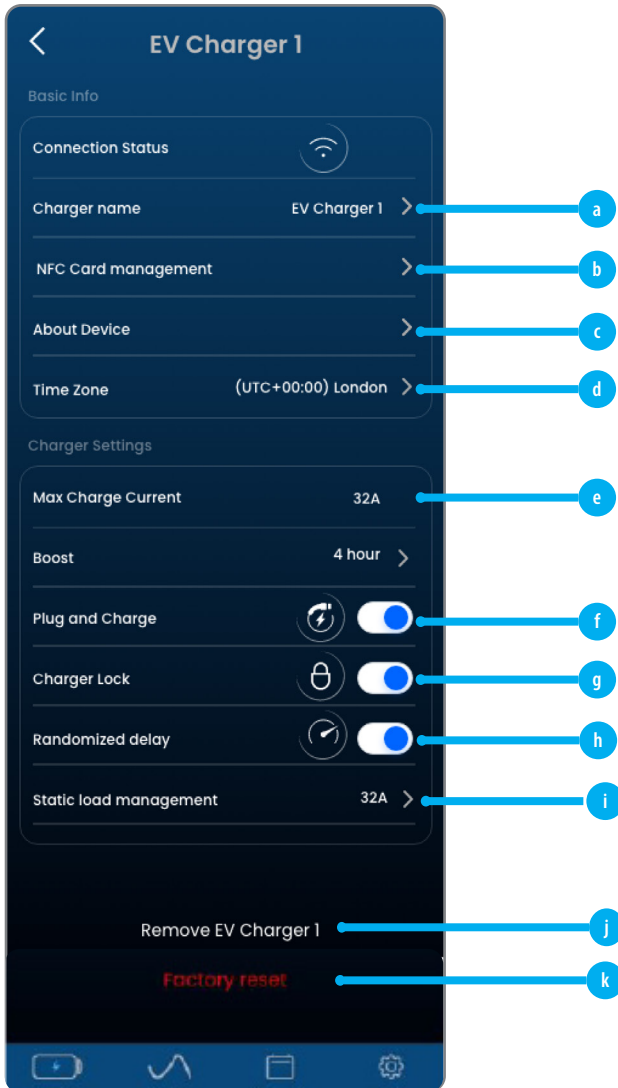

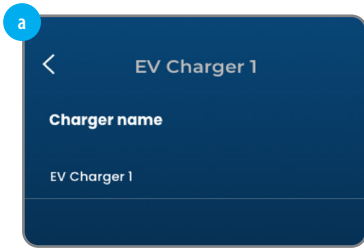

Here the name of the EV charger can be changed.

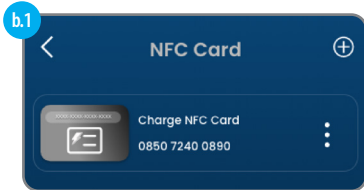

When Plug&Charge is disabled, authorization is required before charging, either by using the App or by swipe NFC card on the EV charger. To manage which NFC card can initiate charging, this screen allows adding new NFC card (by scan QR code or input card number) to the EV charger, and can edit/remove afterwards.

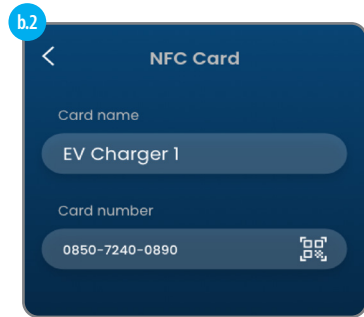

**Each EV charger has its own NFC card list, same card can be added to different EV chargers.*



This screen provides the EV charger information.

It also shows current firmware version and if there is new firmware version available for installation.

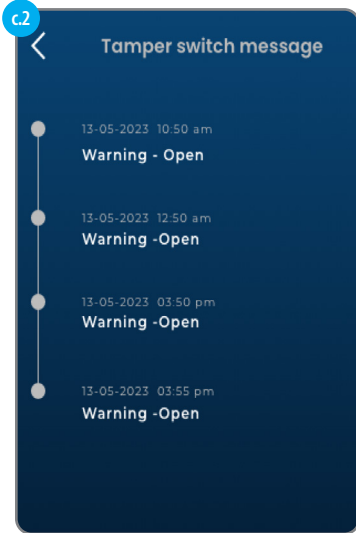

A Tamper switch message log is also available for checking if the EV charger cover has been opened while in operation.

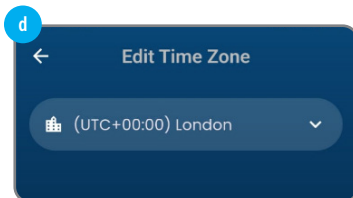

Edit Time & Zone.

Other Charger Settings

Max Charge current

e

It shows the maximum charging current the EV charger can provide. (It is affected by both the SKU and the hardware setting inside the EV charger).

Plug and Charge

f

When enabled, the EV charger can initiate charging without authorization from App or NFC card.

Charging starts right away or after a while depends on if any schedule or randomized delay is applied.

Charger Lock

g

When locked, the EV charger will not provide charging.

Randomized delay

h

When enabled, a randomized delay period (up to 10mins) is applied before starting any charging session.

Static load management

i

This setting can limit the EV charger's output when needed.

Remove

j

Removes the EV charger from the user account.

Factory reset

k

Factory resets will clear all settings, including the Wifi connection to the home router. This reset will also remove the EV charger from the current user account.

Other App Settings

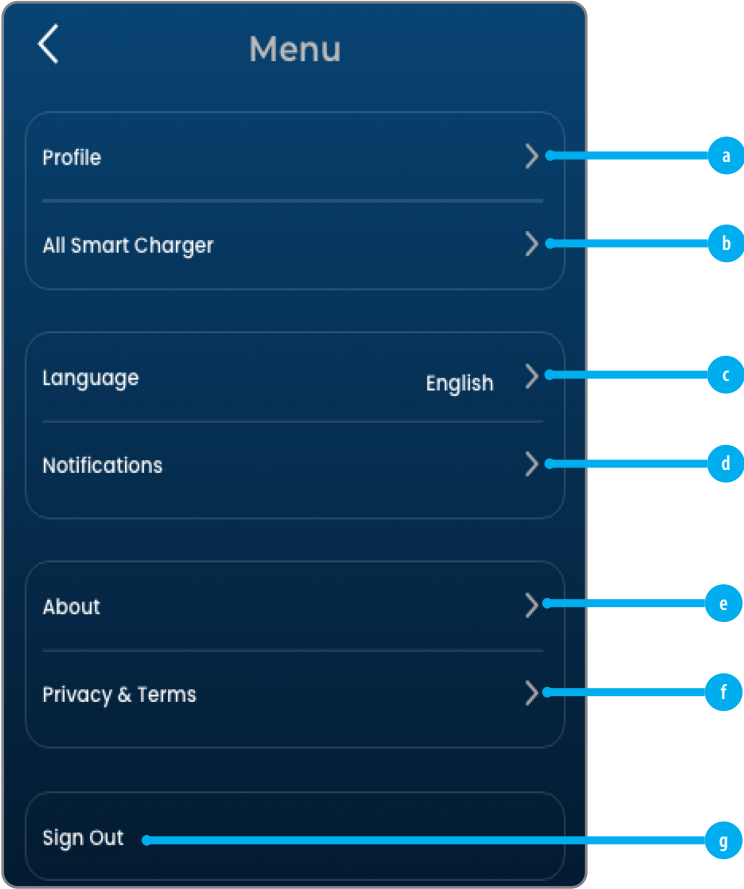

Other App Settings

- a Profile**
User information.

- b All Smart Charger**
Displays all EV chargers added to this user account, and their current status.

- c Language**
Change App display language.

- d Notification**
Enable/Disable App notification when EV charging starts or ends.

- e About**
App information.

- f Privacy & Terms**
Diverts to Privacy & Terms document.

- g Sign out**
Signs out the current user from the App.

Account sign off & Factory reset

When removing the EV charger from your account, the EV charger will also perform a factory reset.

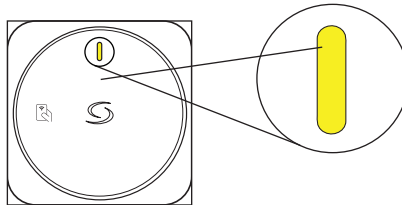

Once finished, the LED on the charger flashes Yellow.

PEN fault protection for EV7UK : 7kW (1-phase) socket type (UK version)

When installed on a PME electrical system it is necessary to protect the user from a potential electric shock that could occur if the combined Neutral and Earth (PEN) conductor on the supply becomes damaged or disconnected.

EV7UK model has an in-built PEN fault protection function, as described in 72.411.4.1 (iv), to disconnect the vehicle from the live, neutral and earth conductors if the voltage is above or below the prescribed levels (greater than 253V and less than 207V). It removes the need for an additional earth electrode or earth rod installation.

*Hereby, Salus Controls., declares that this EV Charger is in compliance with the essential requirements and other relevant provisions of RE Directive 2014/53/EU.
A copy of the full DoC is attached.*

*SALUS Controls
Units 8-10, Northfield Business
Park, Forge Way, Parkgate
Rotherham, S60 1SD*

HEAD OFFICE

SALUS Controls
Units 8-10, Northfield Business
Park, Forge Way,
Parkgate, Rotherham,
S60 1SD, United Kingdom

SALUS Controls GmbH,
Dieselstrasse 34,
63165 Mühlheim am Main,
Germany

Email: sales@salus-tech.com



www.saluscontrols.com

SALUS Controls is a member of the Computime Group

Maintaining a policy of continuous product development SALUS Controls plc reserve the right to change specification, design and materials of products listed in this brochure without prior notice.

V02
10/2024

