



Quick Guide



PRODUCER:
SALUS Controls Plc Units 8-10
Northfield Business Park Forge Way,
Parkgate, Rotherham S60 1SD,
United Kingdom



SALUS Controls is a member of the
Computime Group.

Maintaining a policy of continuous product
development SALUS Controls plc reserve
the right to change specification, design and
materials of products listed in this brochure
without prior notice.

www.saluscontrols.com

Issue Date: June 2019
V031



Introduction

RT510 / RT510TX / RT510RF is a programmable room thermostat used to control room temperature. Device launching heating system by shorting terminal blocks, simultaneously informing the action and showing this information on the LCD display. Extended features allows us to use various operating modes - automatic (time schedules), manual, frost protection or holiday. Before use please read this manual carefully. Use only AA 1.5 V alkaline batteries in the thermostat. Place the batteries into the battery slot located under the cover. Do not use rechargeable batteries.

Product compliance

This product complies with the essential requirements and other relevant provisions of the following EU Directives: EMC 2014/30/EU, LVD 2014/35/EU, RED 2014/53/EU and RoHS 2011/65/EU. Full text of the EU Declaration of Conformity is available on www.saluslegal.com

868.0-868.6MHz; <13dBm

Safety Information

Use in accordance to national and EU regulations. Use the device as intended, keeping it in dry condition. Product for indoor use only. Installation must be carried out by a qualified person in accordance to national and EU regulations.

Technical specification

	RT510 Thermostat	RT510TX Thermostat
Thermostat supply	2 x AA alkaline batteries	2 x AA alkaline batteries
Thermostat rating max	3 (1) A	-
Outputs	Voltage free NO / COM / NC terminals	-
Temperature range	5 - 35°C	5 - 35°C
Temperature accuracy	0.1°C or 0.5°C	0.1°C or 0.5°C
Control algorithm	TPI or hysteresis ±0.25°C	TPI or hysteresis ±0.25°C
Radio frequency	-	868 MHz
Dimension [mm]	120x96x27	120x96x27

RXRT510 Receiver	
Receiver supply	230 V AC
Receiver rating max	16 (5) A
Outputs	Voltage free NO / COM terminals
Radio frequency	868 MHz
Dimension [mm]	96x96x27

Button functions

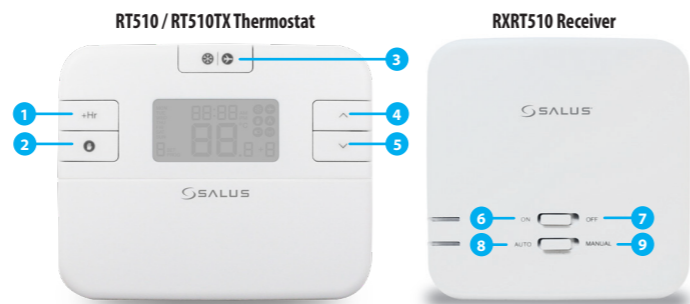

1. Boost function
2. Manual Mode
3. Frost protection / Holiday Mode
4. Increase button
5. Decrease button
6. When in Manual Mode, ON will turn the boiler on.
7. When in Manual Mode, OFF will turn the boiler off.
8. Receiver operates in automatic mode according to the thermostat
9. Receiver output is controlled by the On/Off slide switch.

LCD Icon description

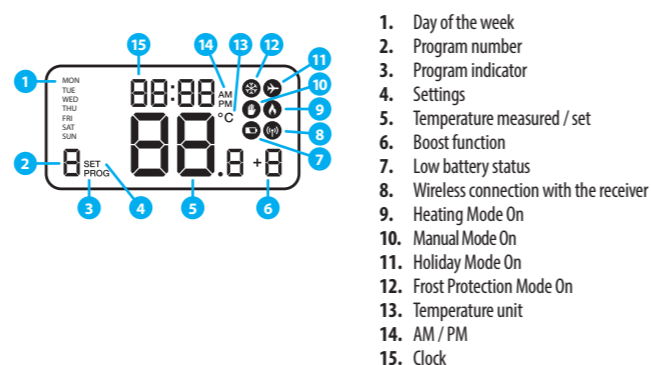

1. Day of the week
2. Program number
3. Program indicator
4. Settings
5. Temperature measured / set
6. Boost function
7. Low battery status
8. Wireless connection with the receiver
9. Heating Mode On
10. Manual Mode On
11. Holiday Mode On
12. Frost Protection Mode On
13. Temperature unit
14. AM / PM
15. Clock

RT510 Terminals description

Terminal	Description
1 - COM	Common Terminal
2 - NC	Switched Live OFF
3 - NO	Switched Live ON

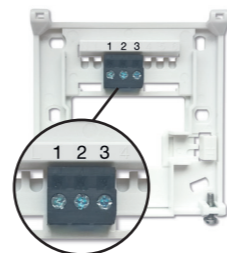

RXRT510 Receiver terminals description

Terminal	Description
NO	Switch Terminal
COM	Common Switch Terminal
L, N	Supply (230 V AC)



DIP Switch Settings

The DIP Switches can be found on the rear of your thermostat.

DIP Switch	Control feature	TPI	Span
1	Operation	When TPI is selected on DIP switch № 2, the DIP switch № 1 is functional. You can choose the Cycles Per Hour between a lower comfort level (6CPH) and a higher comfort level (9CPH).	When Span is selected on DIP switch № 2, the DIP switch № 1 is not functional. The temperature accuracy of your thermostat is set to ± 0.25 °C.

RT510 Wiring diagram

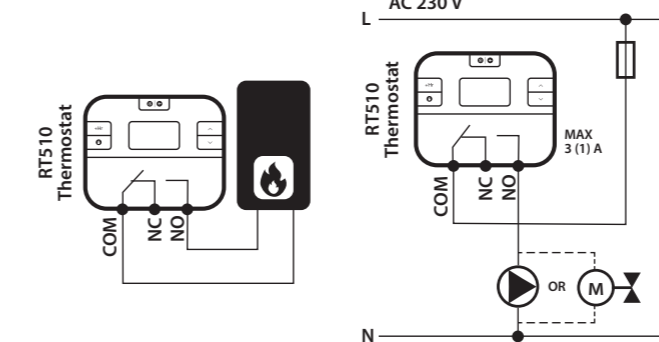

RT510TX Wiring diagram

Note: If you are using the RT510RF pack, the pairing between the thermostat and the receiver is already done.

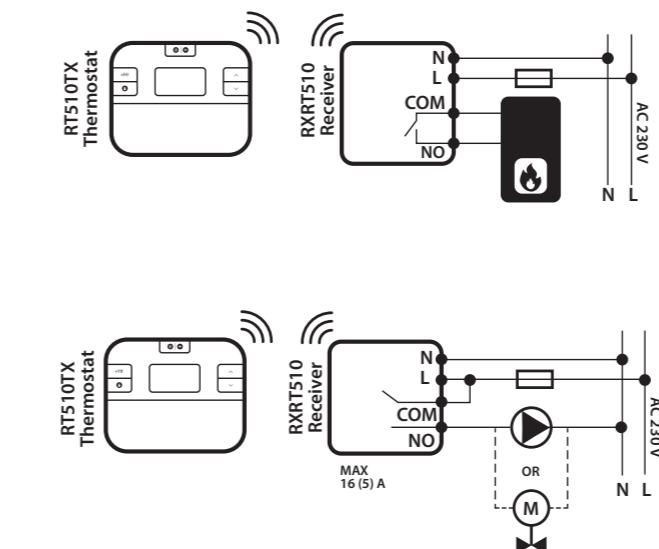

Setting the time

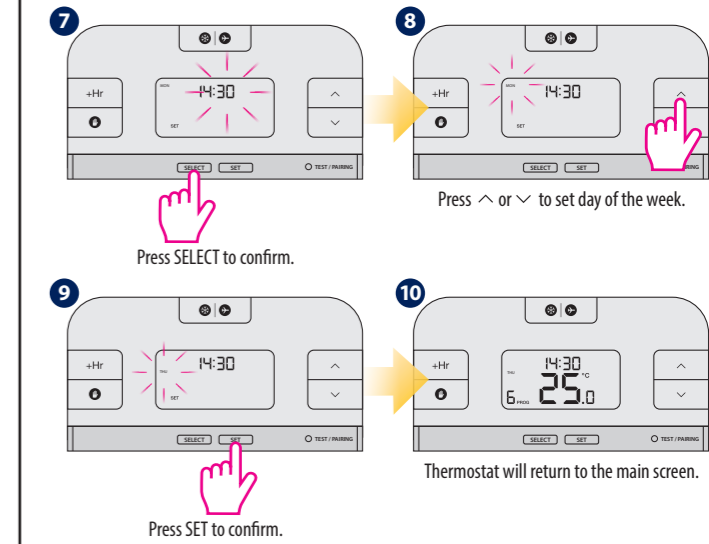
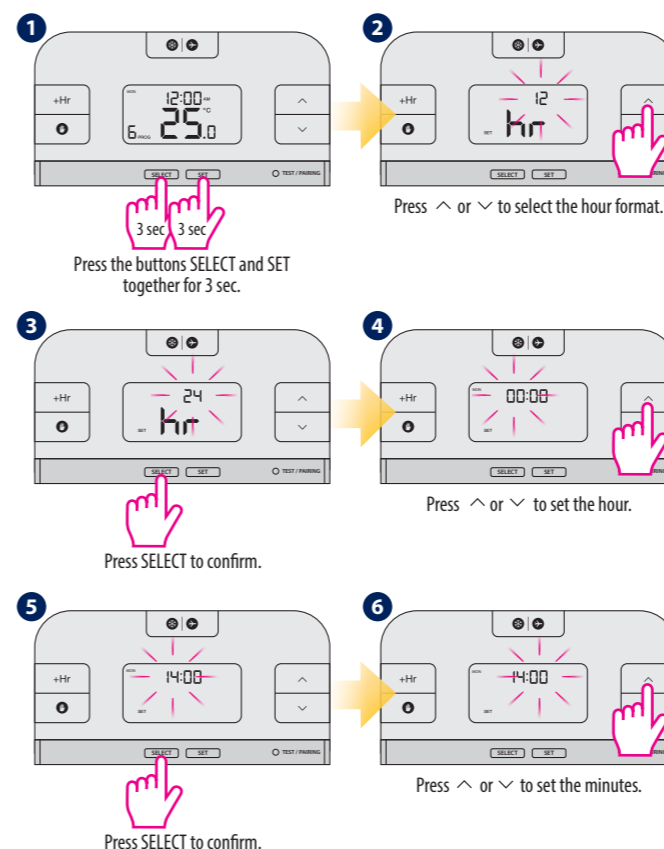

Programming - automatic mode

In this mode, user can set the schedules for thermostat (temperature setpoints for specific periods of time). To do this, firstly choose programming mode: "5-2" (business days + weekend) or "24h" (each day separately) using parameter d04 from Installer mode. Programmed schedules should use all time periods.

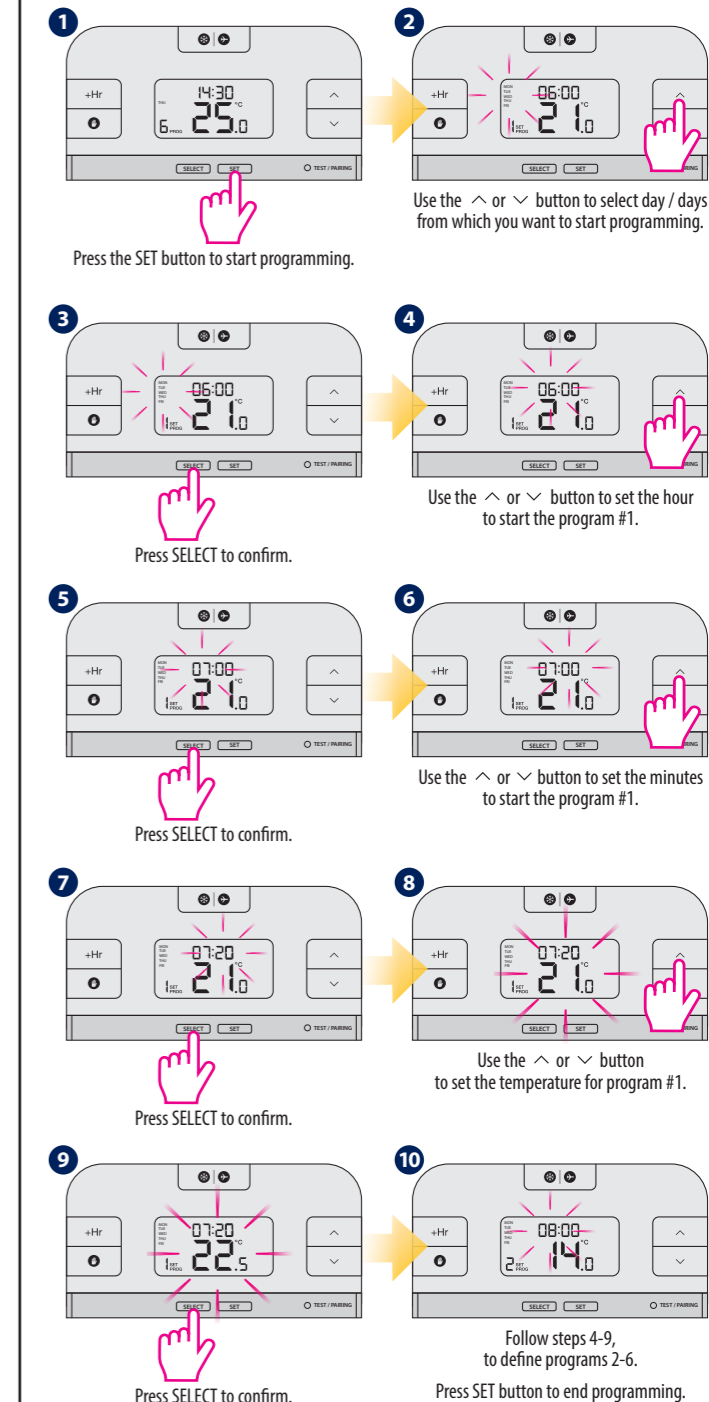

Temporary Override Mode

This function is available only in automatic mode (schedule). If a new setpoint temperature will be set during the schedule - it will be maintained until next time interval starts according to programmed schedule.

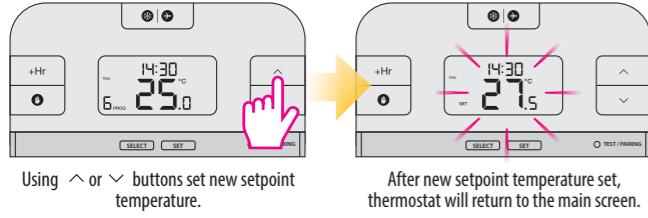

Temporary Override mode will be disabled when new schedule will be set.

Manual Mode and setting setpoint temperature

In this mode thermostat does not work according to the programmed schedule but it will maintain selected temperature.

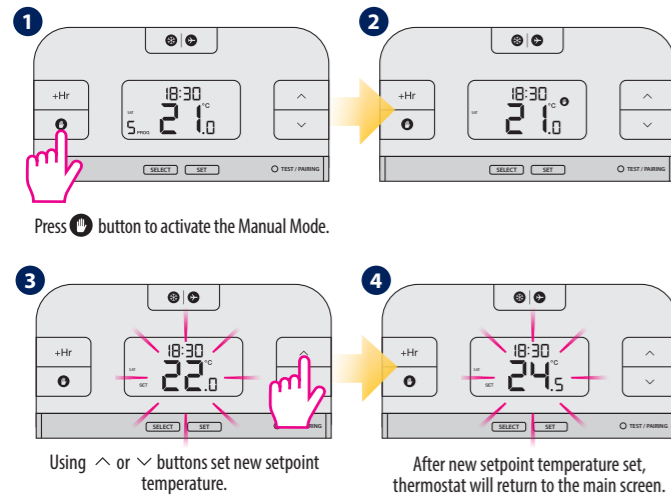

To turn off the Manual Mode press the Manual Mode button. Once the manual mode is off, the hand icon will disappear.

Hourly temperature Override Mode (+Hr)

This function is available in Automatic and Manual Mode. It is used to change the setpoint temperature for a specified number of hours (up to 9 hours). Once that time is over, thermostat returns to previous mode.

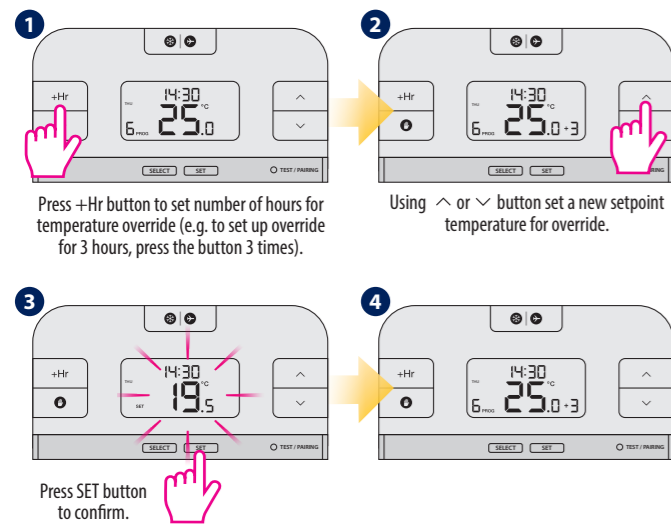

Turning off hourly temperature override mode before time's up

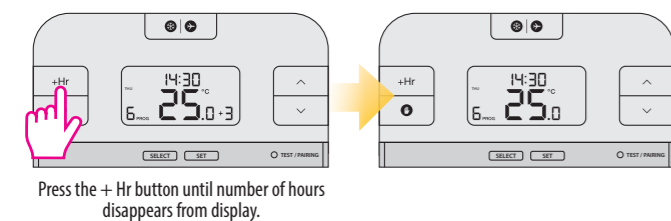

Frost Protection

Temperature of the Frost Protection mode is set as default at 5°C. This temperature can be changed in Installer Mode in d03 parameter.

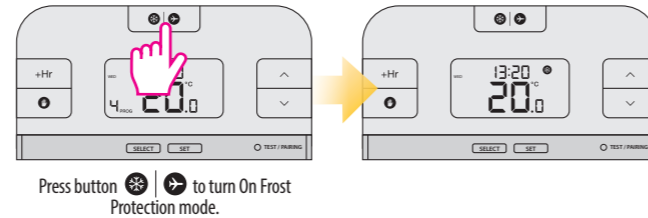

Turning Off the Frost Protection Mode

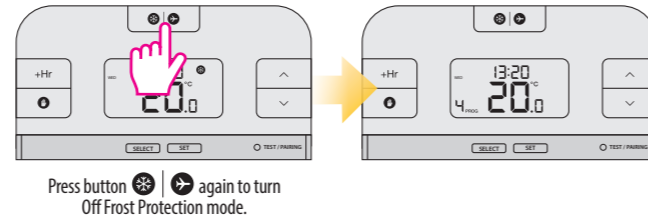

Sleep mode

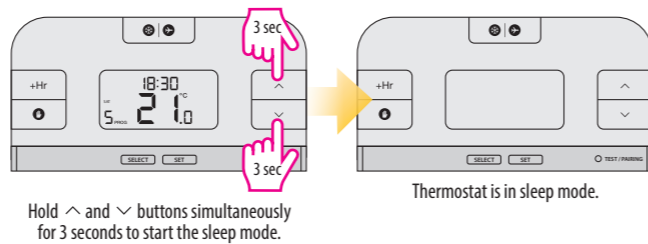

When the sleep mode is activated, all thermostat functions are paused.

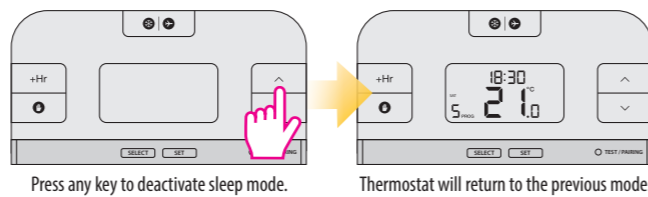

Holiday Mode

In this mode the "frost protection" temperature is maintained for a specific number of days.

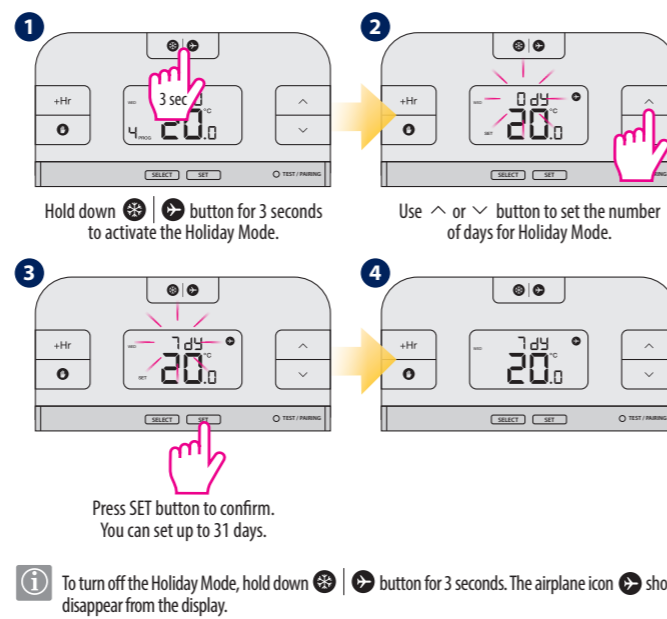

To turn off the Holiday Mode, hold down the Frost Protection button for 3 seconds. The airplane icon should disappear from the display.

RT510TX thermostat pairing with the receiver

Note: If you are using the RT510RF pack, the pairing between the thermostat and the receiver is already done.

If you bought the RT510TX and RXRT510 separately or if you want to re-pair thermostat with the receiver, make sure that the device is disconnected from the power supply and the switches on the receiver have been set to AUTO and ON. Then connect the receiver to the power supply and wait for the red LED to light steadily. Then switch to the OFF position and again to ON position quickly. The red flashing LED will confirm entering the pairing mode.

Begin the pairing process

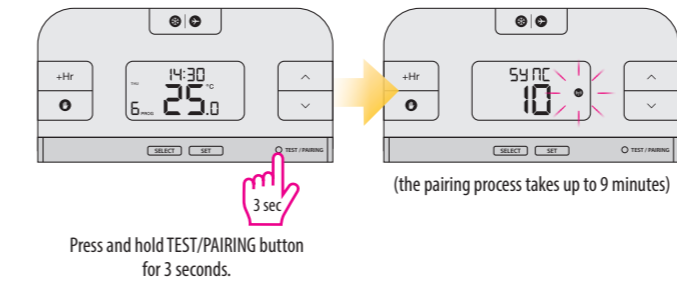

End the pairing process

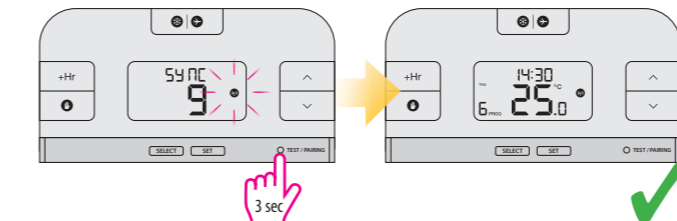

Once devices are successfully paired, LED on the receiver will go solid red. Press and hold TEST / PAIRING button for 3 seconds to end the pairing process.

Test the pairing process

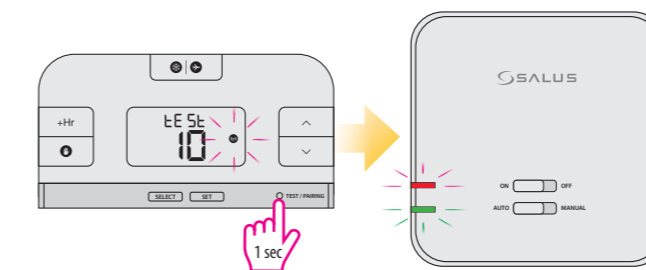

Press TEST / PAIRING button to check the connection with the receiver.

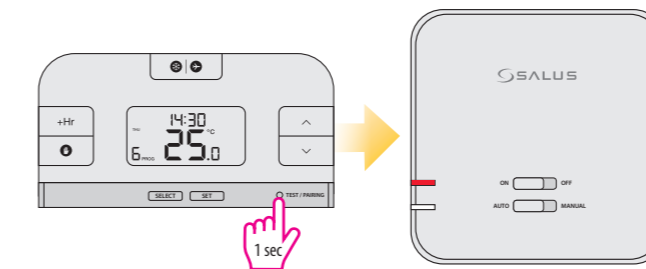

Press TEST / PAIRING button again to return to the main screen.

Installer Mode

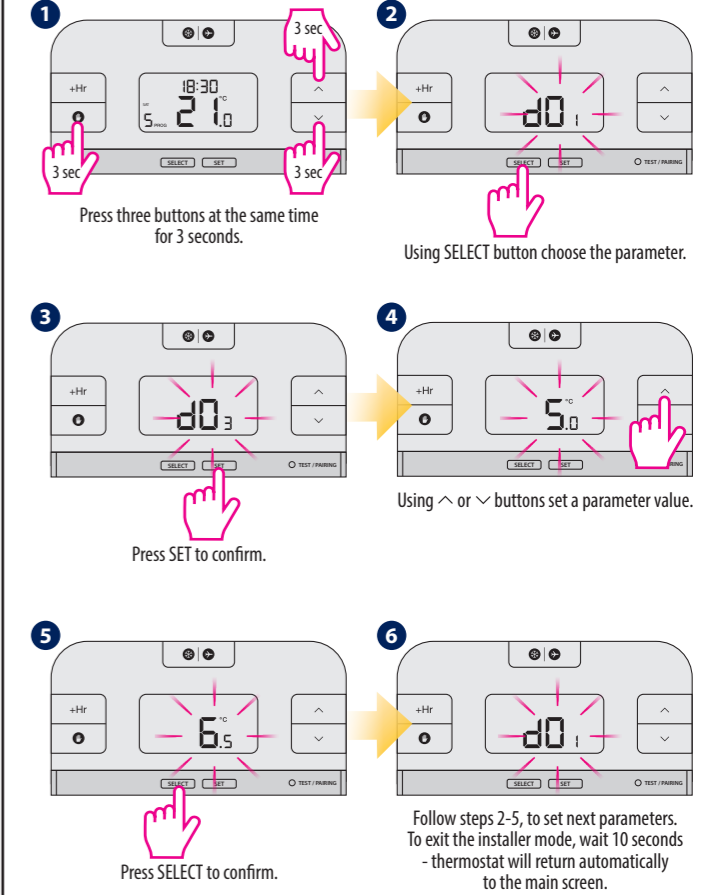

dxx	Function	Parameter	Default value
d01	Temperature display increments	0.1°C or 0.5°C	0.5°C
d02	Temperature offset	+/- 3.0°C	0.0°C
d03	Frost Protection setpoint temperature	5.0°C - 17.0°C	5.0°C
d04	Programmer selection	5/2 or 24 hr (7d)	52d

Reset of the RT510 thermostat

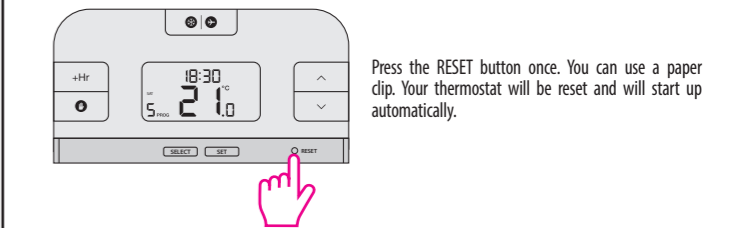

Reset of the RT510TX thermostat

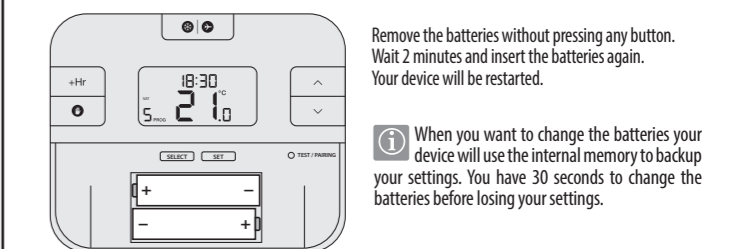

NOTE: If you do not notice the "low battery" symbol displayed on the screen in time, it will shut down. In this case, after removing the old batteries, it is necessary to wait 5 minutes before inserting the new batteries. Otherwise, it is possible that a condenser will remain partially discharged and it can prevent the thermostat from restarting.