



# TRIPLE PHASE INVERTER

Model: INV-WF-10000W-3P, 10KW



Installation Manual



# CONTENTS

1 Safety Precautions .....	4
1.1 Important Safety Instructions .....	4
1.2 Symbol Explanation .....	11
1.3 CE Directives .....	12
2 Introduction .....	14
2.1 Model Description .....	14
2.2 Basic features .....	14
2.3 Dimensions .....	17
2.4 Work modes .....	18
2.5 Terminals .....	22
2.6 Parameters .....	24
3 Installation .....	30
3.1 Check for Physical Damage .....	30
3.2 Packing List .....	30
3.3 Mounting .....	31
3.3.3 Installation Procedure .....	32
4 Electrical Connection .....	35
4.1 PV connection .....	35
4.2 Grid connection .....	37
4.3 EPS Connection (apply to I Version and E Version only) .....	39
4.4 Battery Connection .....	46
4.5 CT Connection and Phase instruction .....	49
4.6 DRM Connection (Function temporarily retained) .....	51

4.7 WiFi Connection (optional).....	52
4.8 Inveretr Manipulation .....	53
5 Setting.....	54
5.1 Control Panel.....	54
5.2 Instructions for LED Indicator.....	54
5.3 Instructions for the use of three modes.....	55
6 LCD Operation.....	58
6.1 LCD Interface.....	58
6.2 Setting.....	63
6.3 Advan set .....	75
6.4 Inquire.....	77
6.5 Statistic.....	78
7 Fault diagnosis and solutions .....	79

## PREFACE

This user manual presents a detailed description of REVO series with respect to product features, structural characteristics, functions, installation, parameter settings, troubleshooting, commissioning and daily maintenance, etc. Be sure to carefully read through the safety precautions before use and keep it properly at a place for easy access.



### IMPORTANT NOTES

---

- Please assure the intactness of product enclosure and all safety covers before installation. Operation must conform to the requirements of this manual and local industrial safety regulations and/or electrical codes.
  - In the event of damage or loss of user manual, users may ask local distributors, offices or our Technical Service Department for a new one.
  - Contents of this manual may be subject to appropriate modification as a result of product upgrade, specification change and update of the manual.
  - If any item as stated in this manual is not clear, please contact our Technical Service Department.
  - If any anomaly occurs after power up or during the operation, it is essential to stop the machine and identify the fault or seek technical services as soon as possible.
-

This manual is valid for the following model of hybrid inverters:

- **INV-WF-10000W-3P**

It will be referred to as "inverter" hereinafter unless otherwise specified.

The inverter must only be installed by professional technicians. The professional technician is required to meet requirements as follows:

- Know electronic, electrical wiring and mechanical expertise, and be familiar with electrical and mechanical schematics.
- Be familiar with local standards and relevant safety regulations of electrical systems.
- Have received professional training related to the electrical equipment installation and commissioning.
- Be able to quickly respond to hazards or emergencies that occur during installation and commissioning.

## TECHNICAL SUPPORT

Before installation, wiring, operation, and repair to the inverter, please read carefully and strictly comply with all its Safety Precautions in this manual.

Please ensure all the warning marks on the inverter are clear and distinct. Replace or add the obscure or missed warning marks.

The information from following sources is all effective.

**E-mail:** UK: [tech@salus-tech.com](mailto:tech@salus-tech.com)  
DE / NL: [info@salus-controls.de](mailto:info@salus-controls.de)  
FR: [technicalsupport@saluscontrols.fr](mailto:technicalsupport@saluscontrols.fr)  
RO: [tehnic@saluscontrols.ro](mailto:tehnic@saluscontrols.ro)  
DK: [Support@salus-controls.dk](mailto:Support@salus-controls.dk)

If you have any question, or anything that it is not clear for you, or have some troubles during installation, wiring, and/or operation, you are suggested to contact us via its recommended contact information in this manual or contact its sales representatives or service engineers.

# 1 Safety Precautions

Safety signs in this manual:

---



**DANGER** indicates high-risk potential hazards that, if not avoided, may lead to death or serious injury.



**WARNING** indicates moderate-risk potential hazards that, if not avoided, may lead to death or serious injury.



**CAUTION** indicates low-risk potential hazards that, if not avoided, may lead to minor or moderate injury.



**NOTE** provides valuable tips on the best operation of our products.

---

## 1.1 Important Safety Instructions

---

Danger to life due to a high voltage inside the inverter!



- All work must be performed by a qualified electrician.
  - Children and persons with reduced physical sensory abilities, mental capabilities, or lack of experience and knowledge should not use this equipment unless supervised or instructed.
-



---

### Danger of burns



- When the product is working, the upper of the enclosure and the enclosure body may become hot.
  - During operation, only the touch screen needs to be operated.
- 
- 



### Radiation may cause damage to health.

- Do not stay at a place less than 20cm away from the inverter for a long time.
- 
- 

### Ground the PV generator.



- Comply with the local requirements for grounding the PV modules and the PV generator.
  - It is recommended that generator frames and other conductive surfaces be connected in a manner that ensures continuous conduction and grounding for optimum protection of the system and personnel.
- 
- 



Make sure the input DC voltage is less than the maximum value. Over-voltage may cause permanent damage to the inverter or other losses, which will not be covered by the warranty!

---

---



Before attempting any maintenance, cleaning or working on any circuits connected to inverter, authorized service personnel must disconnect both AC and DC power from inverter.

---



Do not operate the inverter while the equipment is running.

---

---



Risk of electric shock!

---

- It is recommended to use only accessories that are compatible with the inverter, otherwise it may lead to the risk of fire, electric shock or personal injury.
- Make sure the existing wiring is in good condition, and the wires are not undersized.
- Please do not disassemble any parts of the inverter that are not mentioned in the installation guide. The inverter contains no user-serviceable parts. If service is required, please refer to the warranty information. Unauthorized repairs may result in the risk of electric shock or fire, and will void your warranty.
- Keep away from flammable, explosive materials to avoid fire disaster.
- The installation location should be away from humid or corrosive substance.
- Authorized service personnel must use insulated tools when installing or working with this equipment.
- PV modules should have IEC 61730 Class A rating.
- Do not touch either the positive or negative pole of PV connecting device. Strictly prohibit touching both of them at the same time.
- The unit contains capacitors that remain charged to a potentially lethal voltage when the MAINS , battery and PV supply has been disconnected.
- Hazardous voltages may remain present for up to 5 minutes after disconnection.
- CAUTION-The energy stored in the capacitor is a shock hazard, do not operate the inverter, coupler, power cable, battery cable, PV cable or PV generator while energized. After turning off the PV, battery and power supply, always wait 5 minutes to allow the

intermediate circuit capacitors to discharge before unplugging the DC, battery and power coupler.

- When accessing the internal circuit of inverter, it is very important to wait 5 minutes before operating the power circuit or demounting the electrolyte capacitors inside the device. Do not open the device beforehand since the capacitors require time sufficiently discharge!
- Measure the voltage between terminals  $U_{DC+}$  and  $U_{DC-}$  with a multi-meter(impedance at least 1Mohm) to ensure that the device is discharged ( <35VDC ) before starting to work inside the device.

### 1.1.1 Install surge protection devices (SPDs) for PV

---



WARNING

- Over-voltage protection with surge arresters should be provided when installing PV power generation system.
  - The grid connected inverter does not have SPDs installed on both PV input side and MAINS side.
- 
- Lightning will cause a damage either from a direct strike or from surges due to a nearby strike.
  - Induced surges are the most likely cause of lightning damage in majority or installations, especially in rural areas where electricity is usually provided by long overhead lines. Surge may be included on both the PV array conduction and the AC cables leading to the building.
  - Specialists in lightning protection should be consulted during the end use application.

- Using appropriate external lightning protection, the effect of a direct lightning strike into a building can be mitigated in a controlled way, and the lightning current can be discharged into the ground.
- Installation of SPDs to protect the inverter against mechanical damage and excessive stress include a surge arrester in case of a building with external lightning protection system (LPS) when separation distance is kept.
- To protect the DC system, surge suppression device (SPD type2) should be fitted at the inverter end of the DC cabling and at the array located between the inverter and the PV generator, if the voltage protection level (VP) of the surge arresters is greater than 1100V, an additional SPD type 3 required for surge protection for electrical devices.
- To protect the AC system, surge suppression devices (SPD type2) should be fitted at the main incoming point of AC supply (at the consumer's cutout), located between the inverter and the meter/distribution system; SPD (test impulse D1) for signal in according I to EN 61632-1.
- All DC cables should be installed to provide as short a run as possible, and positive and negative cables of the string or main DC supply should be bundled together. Avoiding the creation of loops in the system.
- Spark gap devices are not suitable to be used in DC circuits once conducting, they won't stop conducting until the voltage across their terminals is typically more than 30 volts.

### **1.1.2 Anti-Islanding Effect**

The islanding effect is a special phenomenon where a grid-connected PV system still delivers power to the nearby grid when voltage losses occur in the power system. This can be dangerous for maintenance personnel and the public. The Revo series inverters offer Active Frequency Drift (AFD) to prevent the islanding effect.

### 1.1.3 PE Connection and Leakage Current

- The end-use application shall monitor the protective conductor by residual current operated protective device (RCD) with rated fault current  $I_{fn} \leq 240\text{mA}$  which automatically disconnects the device in case of a fault. The device is intended to connect to a PV generator with a capacitance limit of about 700nf.



High leakage current!

Earth connection essential before connecting supply.

---

- Incorrect grounding can cause physical injury, death or equipment malfunction and increase electromagnetic.
- Make sure that grounding conductor is adequately sized as required by safety regulations.
- Do not connect the ground terminals of the unit in series in case of a multiple installation. This product can cause current with a DC component, Where a residual current operated protective (RCD) or monitoring (RCM) device is used for protection in case of direct or indirect contact, type A or type B RCD or RCM is allowed on the supplier of this product.

### 1.1.4 For United Kingdom

- The installation that connects the equipment to the supply terminals shall comply with the requirements of BS 7671.

- Electrical installation of PV system shall comply with requirements of BS 7671 and IEC 60364-7-712.
- No protection settings can be altered.
- User shall ensure that equipment is so installed, designed and operated to maintain at all times compliance with the requirements of ESQCR22(1)(a).
- Make sure that grounding conductor is adequately sized as required by safety regulations.
- Do not connect the ground terminals of the unit in series in case of a multiple installation. This product can cause current with a DC component, Where a residual current operated protective (RCD) or monitoring (RCM) device is used for protection in case of direct or indirect contact, type A or type B RCD or RCM is allowed on the supplier of this product.

#### **1.1.5 For Australia and New Zealand**

Electrical installation and maintenance shall be conducted by licensed electrician and shall comply with Australia National Wiring Rules.

#### **1.1.6 Battery Safety Instructions**

Revo series hybrid inverter should be worked with high voltage battery, for the specific parameters such as battery type, nominal voltage and nominal capacity etc., please refer to section 4.







As accumulator batteries may contain potential electric shock and short-circuit current danger, to avoid accidents that might be thus resulted, the following warnings should be observed during battery replacement:



- 1: Do not wear watches, rings or similar metallic items.
- 2: Use insulated tools.
- 3: Put on rubber shoes and gloves.
- 4: Do not place metallic tools and similar metallic parts on the batteries.

- 5: Switch off load connected to the batteries before dismantling battery connection terminals.
- 6: Only personal with proper expertise can carry out the maintenance of accumulator batteries.

## 1.2 Symbol Explanation

This section gives an explanation of all the symbols shown on the inverter and on the type label.

Symbol	Explanation
	CE mark. The inverter complies with the requirements of the applicable CE
	TUV
	RCM remark
	Beware of hot surface. The inverter can become hot during operation. Avoid contact during operation.
	Danger to life due to high voltages in the inverter!
	Danger. Risk of electric shock!
	Please note the provisions of the instruction manual.
	The inverter can't be disposed together with the household waste.

Symbol	Explanation
	Do not operate inverter until it is isolated from battery, mains and on-site PV generation suppliers.
	Danger to life due to high voltage.
	There is residual voltage existing in the inverter after powering off. Which needs 5 min to discharge. Wait 5 min before you open the upper lid or the DC lid.

### 1.3 CE Directives

This chapter follows the requirements of the European Low Voltage Directive, which contains safety instructions and conditions of acceptance for imported systems that you must follow when installing, operating and servicing the equipment. If ignored, it may result in personal injury or death, or damage to the equipment. Please read this before you perform work on the equipment. If you cannot understand these hazards, warnings, cautions, or instructions, contact an authorized service dealer to operate and maintain the equipment prior to installation.

The grid-connected inverter meets the requirements of IEC 62109-1/-2; IEC 62477-1; IEC 61000-6-1/-3.

If installed in a PV system, it is forbidden to start the unit (i.e. to start the specified operation) until it has been established that the entire system complies with the requirements specified in the CE Directive, that the grid-connected inverter is shipped with the connection device completed and ready for connection to the mains and PV power supply, and that the unit is installed in compliance with the national wiring regulations. Compliance with safety regulations depends on proper installation and configuration of the system, including the use of the specified wiring.



The system must be installed only by professional assemblers who are familiar with safety and EMC requirements. It is the responsibility of the assembler to ensure that the final system complies with all relevant laws of the country of use.

The individual subassemblies of the system should be interconnected by national/international such as the wiring methods listed in the National Electrical Code (NFPA) Regulation No. 70 or VDE Regulation 0107.

## 2 Introduction

### 2.1 Model Description

The model description is as follows (take INV-WF-10000W-3P as an example):

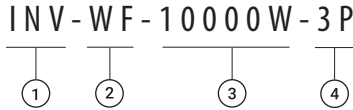

- ① INV : Inverter
- ② WF : Wi-Fi
- ③ 10000W : Power rating 10,000W
- ④ 3P : Triple Phase

---

### 2.2 Basic features

Revo Hybrid Series is a high performance inverter that converts solar energy to DC power and stores the energy in batteries.

The inverter can be used to optimize its own energy consumption, to store energy in batteries for future use or to connect to the public grid. The mode of operation depends on the PV energy source and user preferences. It can use the energy from the batteries and the inverter (generated by the PV) to provide emergency power in case of grid outages.

Revo Hybrid Series is designed in two EPS versions for customers to choose from based on local rules.

E-Version applies to wiring rules that require the N (neutral) wire of the EPS to be disconnected from the N (neutral) wire of the grid (applicable to most countries).

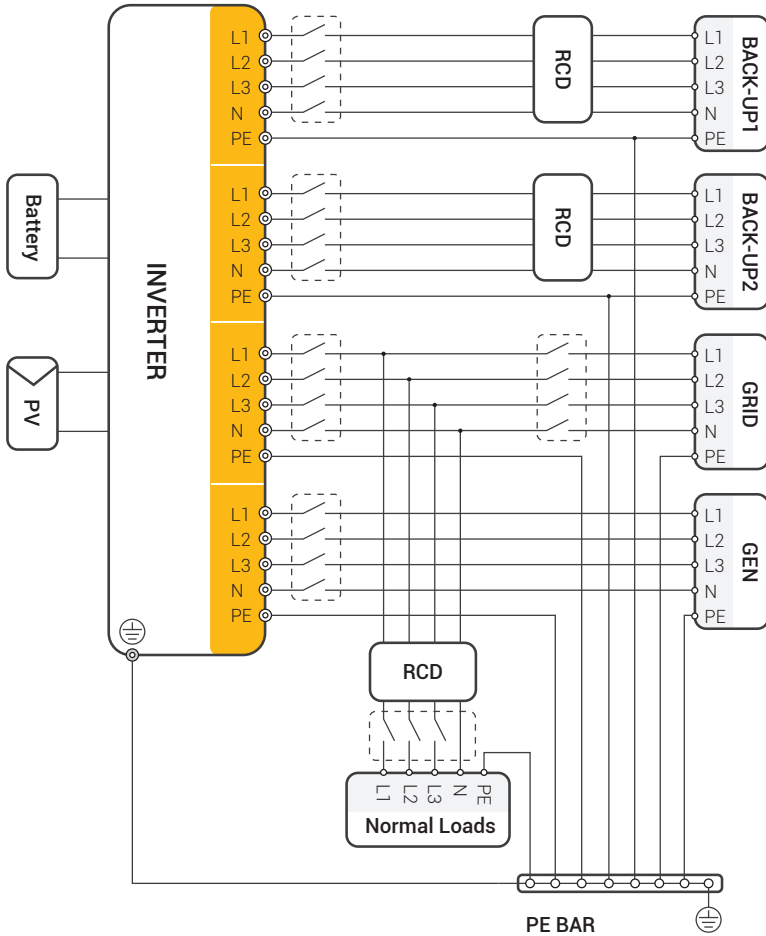

The grounding screw hole of inverter is at the lower right corner.

I-Version applies to wiring rules that require that the N (neutral) wire of other power sources must not be isolated or switched (applicable to Australian and New Zealand wiring rules AS/NZS\_3000:2012).

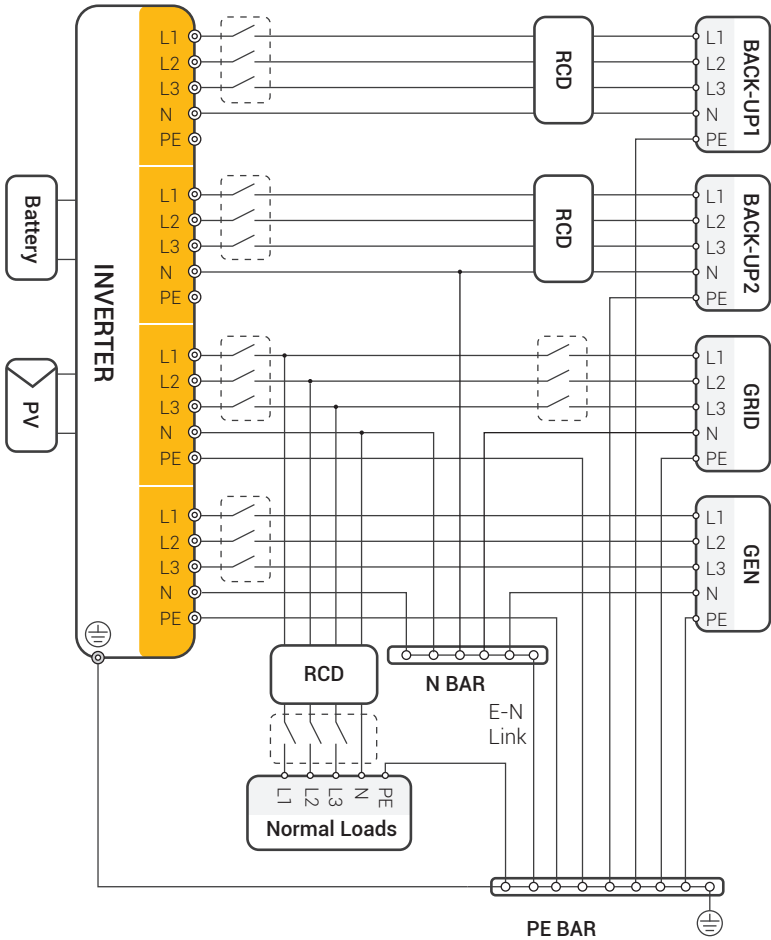

The grounding screw hole of inverter is at the lower right corner.



- In EPS mode, ensure that the load power connected to the load port of the inverter is lower than EPS rated output power, otherwise, the inverter will shutdown and send the “Over Load” fault alarm.
- Please check with the main grid operator for any special grid connection regulations.
- The wiring diagram is for reference only and the complete electrical connection should comply with the local regulations.
- Do not misconnect the phase sequence. Otherwise, the inverter will not operate properly.

## 2.3 Dimensions

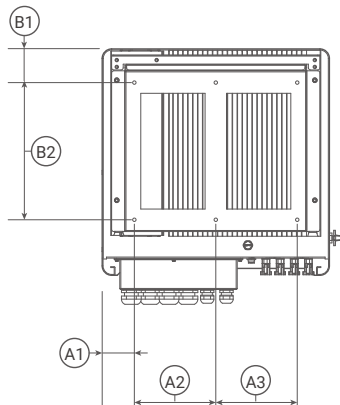
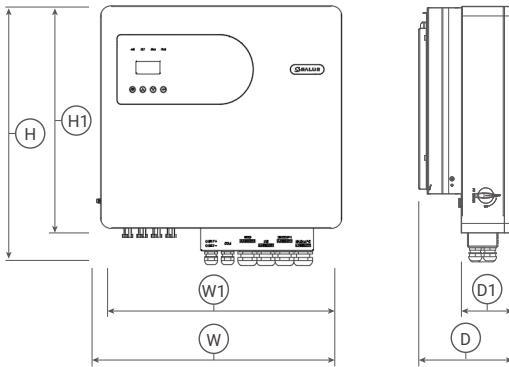

INV-WF-10000W-3P						
W	H	D	W1	H1	D1	Mounting hole dia.
566	596	200	530	528	120	8
A1	A2	A3	B1	B2		
75	190	190	79	320		

*Unit, mm*

## 2.4 Work Modes

The inverter offers multiple working modes according to different requirements.

Work mode: self-use

I. When PV, Grid, Battery is available:

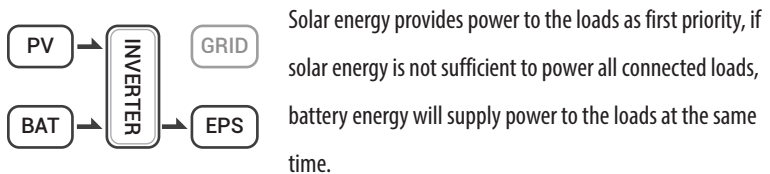
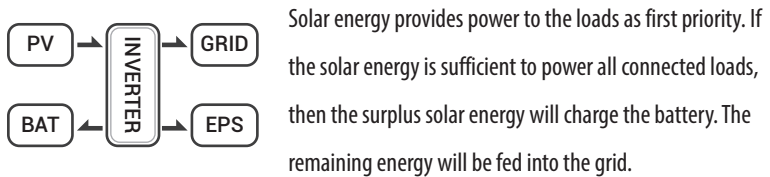

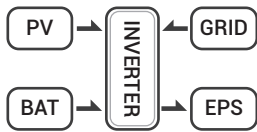

Solar energy provides power to the loads as first priority, if solar energy and battery are not sufficient to power all connected loads, utility energy (Main Grid) will supply power to the loads with solar energy at the same time.

II. When PV, Grid is available (without battery):

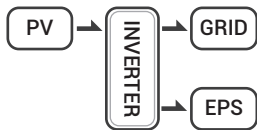

Solar energy provides power to the loads as first priority, if solar energy is sufficient, the excess power will be fed to grid.

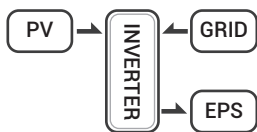

Solar energy provides power to the loads as first priority, if solar energy is not sufficient to power all connected loads, Grid energy will supply power to the loads at the same time.

III. When PV, Battery is available (Grid is disconnected):

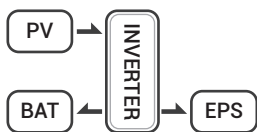

Solar energy provides power to the loads as first priority, if solar energy is sufficient to power all connected loads, solar energy will provide to charge battery.

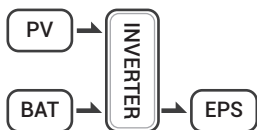

Solar energy provides power to the loads as first priority, if solar energy is not sufficient to power all connected loads, battery energy and solar energy will supply power to the loads at the same time.

Work mode: peak shift

I. When PV, Grid, Battery is available:

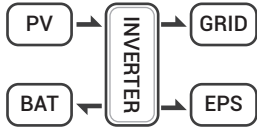

On charge time, solar energy will charge battery as first priority. The excess energy will supply power to the loads. If solar energy is sufficient to supply loads and charge battery, and if there's still some extra energy, then the excess power

will feed the power to grid.

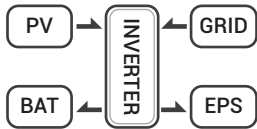

On charge time, solar energy will charge battery as first priority, then the excess solar energy will supply power to loads. If solar energy is not sufficient to charge battery and supply loads, grid will supply all the connected loads with solar energy together.

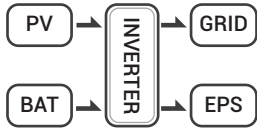

On discharge time, solar energy provides power to the loads as first priority, if solar energy is sufficient to supply loads, and if there's still some extra energy from solar energy, then the excess power and battery will deliver the power to the grid at the same time.

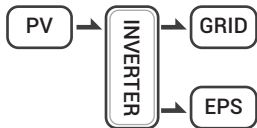

In the period of no charge or discharge, the solar power supply loads at first priority, excess energy will be fed to the grid.



II. When Grid, Battery is available(PV is disconnected):

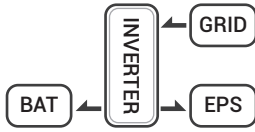

On charge time, grid will charge battery and supply power to the connected loads at the same time.

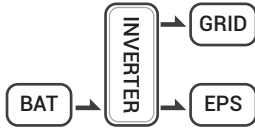

On discharge time, if load power is less than battery power, battery will supply power to loads as first priority, the excess power will be fed to grid.

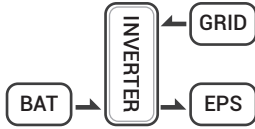

On discharge time, if load power is more than battery power, battery and grid will supply power to the loads at the same time.

Work mode: BAT priority

I. When PV, Grid, Battery is available:

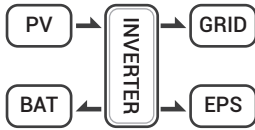

Solar energy will charge battery as first priority, if solar energy is excess, the excess power will supply load. If there's still some extra energy, then the excess power will be fed to grid.

Solar energy will charge battery as first priority, if solar energy is excess the excess power will

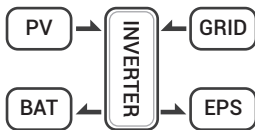

supply load. If solar energy is not sufficient to charge battery and supply loads, grid will supply power to loads.

II. When Grid, Battery is available(PV is disconnected):

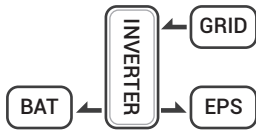

Grid will supply power to load and charge battery at the same time.



If the anti-reflux function is set to be allowable, the system will not feed power to grid in self-use, peak shift, battery priority modes.

## 2.5 Terminals

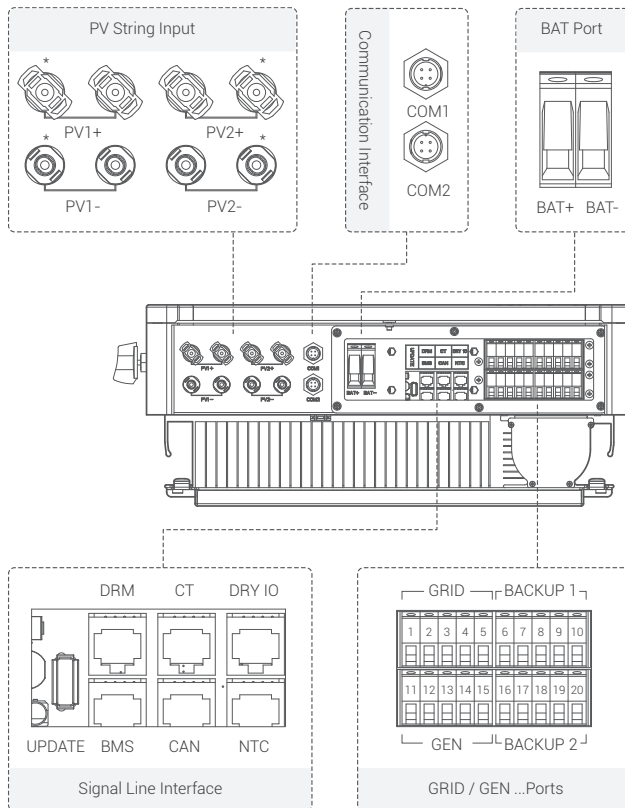

---

<b>PV1+</b>	PV string 1 positive input
<b>PV1-</b>	PV string 1 negative input
<b>PV2+</b>	PV string 2 positive input
<b>PV2-</b>	PV string 2 negative input
<b>COM1</b>	485 port
<b>COM2</b>	WIFI port (optional) and GPRS port(optional)
<b>BAT+</b>	Battery positive input
<b>BAT-</b>	Battery negative input
<b>UPDATE</b>	Port for upgrading software
<b>DRM</b>	Supports multiple demand response modes by sending control signals
<b>CT</b>	Connect to CT (current transformer)
<b>DRY IO</b>	Dry contact
<b>BMS</b>	BMS communication with battery
<b>CAN</b>	CAN communication
<b>NTC</b>	NTC detection

---



---

## **GRID**

<b>1</b>	Grid line A phase
<b>2</b>	Grid line B phase
<b>3</b>	Grid line C phase
<b>4</b>	Grid line neutral line
<b>5</b>	Grid line ground electrode
<b>Backup 1</b>	
<b>6</b>	Backup1 line A phase
<b>7</b>	Backup1 line B phase
<b>8</b>	Backup1 line C phase
<b>9</b>	Backup1 line neutral line
<b>10</b>	Backup1 line ground electrode

---

---

**GEN**

11	A phase
12	B phase
13	C phase
14	Neutral line
15	Ground electrode

**Backup 2**

16	Backup2 line A phase
17	Backup2 line B phase
18	Backup2 line C phase
19	Backup2 line neutral line
20	Backup2 line ground electrode

---

## 2.6 Parameters

### PV input

Model	INV-WF-10000W-3P	
Max. power of PV array	15kW	
Max. PV voltage	1000V	
MPPT voltage range	180V~850V	
Min. input voltage/start voltage	125V/180V	
Full Power MPPT Voltage Range	430-850V	
Rated input voltage	700V	
No. of MPPT trackers	2	
No. of Strings per MPPT tracker	1+1	
Max. input current per MPPT tracker	13A/13A	18A/18A
Max. short-circuit current per MPPT tracker	16A/16A	25A/25A

## Battery

Model	INV-WF-10000W-3P
Battery type	Lithium and Lead Acid Battery
Battery voltage range	125V ~ 600V
Battery operating voltage range	150V ~ 550V
Max. charging power / discharging power	11kW
Max. charging current / Max. discharging current	50A/50A
Rated. charging current / Rated. discharging current	40A/40A

## AC output

Model	INV-WF-10000W-3P
Nominal AC voltage	3W+N+PE, 220/380V; 230/400V; 240/415V
AC voltage range	360V~440V
Rated AC grid frequency	50Hz/60Hz
AC grid frequency range	50±5Hz/60±5Hz
Rated active power	10kW
Rated apparent power	10kVA
Max. apparent power	11kVA
Rated grid output current (@400V)	14.4A
Max. grid output current	15.9A
Harmonics THDI (@ Nominal power)	< 3%

## AC input

Model	INV-WF-10000W-3P
Rated grid voltage	3W+N+PE, 220/380 V; 230/400V; 240/415V
Rated grid frequency	50Hz / 60Hz
Rated active power	20kW
Max. apparent input power from grid	22kVA
Rated input current from grid	28.9A
Max. input current from grid	31.9A

## Backup output

Model	INV-WF-10000W-3P
Nominal output voltage	3W+N+PE, 220/380V; 230/400V; 240/415V
Rated output frequency	50Hz/60Hz
Rated active power	6kVA
Max. apparent output power	6.6kVA
Peak active output power	6.6kVA
Rated Current (@400V)	8.7A
Max. output current	9.5A
Max. switch time	≤10ms
Output THDI (@ Linear load)	<2%

## Efficiency

Model	INV-WF-10000W-3P
MPPT efficiency	≥99.5%
Max efficiency	97.90%
Euro efficiency	97.20%
Max. battery to load efficiency	97.50%

## Safety protection

Model	INV-WF-10000W-3P
DC-side disconnection device	○
PV string reverse polarity protection	○
All-pole sensitive residual current monitoring unit	○
Anti-islanding protection	○
AC output over current protection	○
AC output short circuit current protection	○
AC over voltage protection	○
Protection class (as per IEC 62109-1)	I
Over voltage category (as per IEC 62109-1)	AC: III; DC: II

## General data

Model	INV-WF-10000W-3P
Power factor at rated power / adjustable displacement	0.99 / 0.8 leading to 0.8 lagging
Dimensions (W / H / D)	566 / 596 / 220 mm
Device weight	32kg
Installation	Wall-mounted
Operating temperature range	-25 °C~+60 °C
Noise emissions (typical)	< 35 dB(A)
Standby consumption	< 20 W
Cooling method	Natural convection
Ingress protection rating (as per IEC 60529)	IP65
Climatic category (according to IEC 60721-3-4)	4K4H
Max. permissible value for relative humidity (non-condensing)	0~95%
Max. operating altitude	4000m (>2000m power derating)

## Features

Model	INV-WF-10000W-3P
Inverter topology (PV / battery)	Transformer less / Transformer less
User interface	LED & App
Communication with BMS	CAN
Communication with meter	RS485
Communication with portal	WIFI stick
Integrated power control / Zero export control	o/o



**Standard Compliance**

<b>Model</b>	<b>INV-WF-10000W-3P</b>
Safety	EN 62109-1, EN 62109-2
EMC	IEC 61000-6-1/-2/-3/-4, IEC 61000-3-11, IEC61000-3-12

## 3 Installation

### 3.1 Check for Physical Damage

Make sure that the inverter is intact during shipment. If there is any visible damage, such as cracks, please contact your dealer immediately.

### 3.2 Packing List

Open the package and take out the product, please check the accessories first. The package list is shown below.

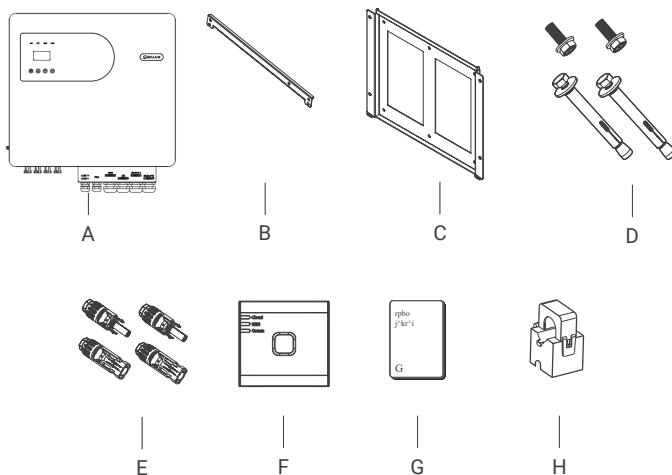

No.	Description	No.	Description
A	Inverter	E	PV connectors (8K~12K: 2×positive, 2×negative; 15k: 4×positive, 4×negative)
B	Crossbar	F	WIFI module (optional)
C	Bracket	G	User manual
D	Expansion screws and pan-head screws	I	Current transformer(CT)

## 3.3 Mounting

### 3.3.1 Installation Precaution

REVO Series hybrid inverter is designed for outdoor installation (IP 65). Please ensure that the installation location meets the following conditions:

- Not in direct sunlight.
- Not in areas where highly flammable materials are stored.
- Not in potential explosive areas.
- Not in the cool air directly.
- Not near the television antennas or antenna cables.
- Not higher than altitude of about 2000m above sea level.
- Not in environment of precipitation or humidity (>95%).
- Under good ventilation conditions.
- The ambient temperature is between  $-20^{\circ}\text{C}$  and  $+60^{\circ}\text{C}$ .
- The slope of the wall should be within  $\pm 5^{\circ}\text{C}$ .
- The wall hanging the inverter should meet the following conditions:
  - i. Solid brick/concrete, or a mounting surface of comparable strength;
  - ii. Inverter must be supported or reinforced if the wall's strength isn't enough (such as wooden wall, the wall covered by a thick decorative layer)

Please AVOID direct sunlight, rain exposure, snow accumulation during installation and operation.



No direct sunlight



No rain exposure



No snow accumulation

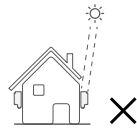

Direct sunlight



Rain exposure



Snow accumulation

### 3.3.2 Space Requirement

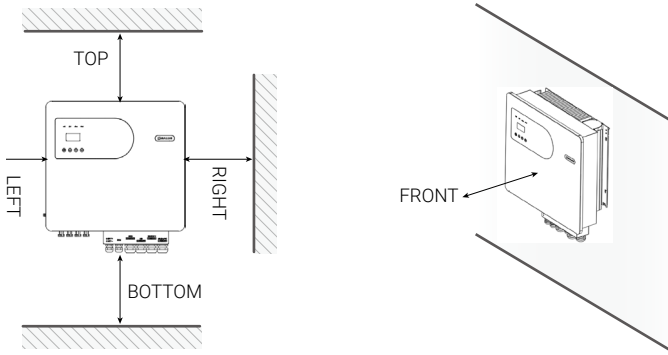

Directions	TOP	BOTTOM	LEFT	RIGHT	FRONT
Min. size (mm)	300	300	300	300	300

### 3.3.3 Installation Procedure

Tools:

Terminal blocks, RJ45 crimping pliers, screwdrivers, hand wrenches and drills, etc.



### Step 1: Mounting the wall bracket on the wall

1. Place the bracket on the wall, mark the location of the four holes and then remove it.
2. Drill holes with an drill, making sure they are deep enough (at least 60 mm) to support the inverter.
3. Install the expansion tubes in the holes, and tighten them. Then install the wall bracket with the expansion screws.

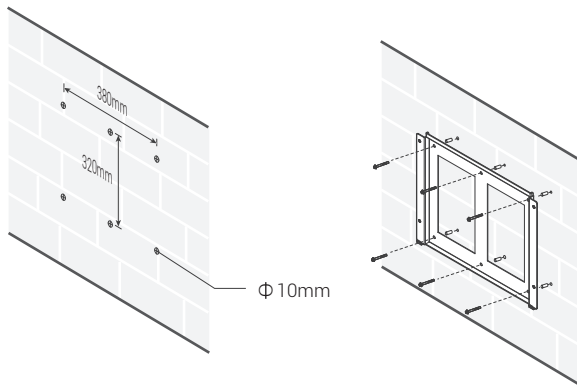

Step 2: Use the screws to fix the crossbar as shown in the figure below.

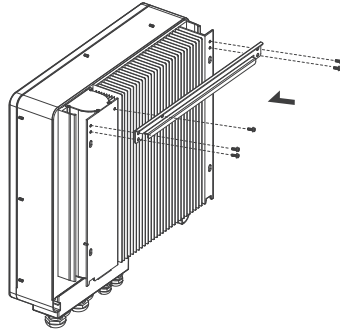

Step 3: Place the inverter on the wall-mounted bracket by holding the handle on the side.

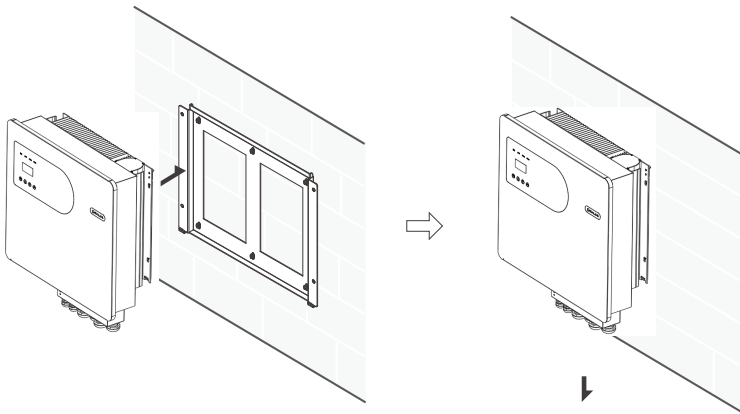

Step 4: Tighten the fixing screws on both sides of the inverter.

Step 5: If necessary, an anti-theft lock can be installed on the lower left side of the inverter.

## 4 Electrical Connection

### 4.1 PV connection

You can select two strings of PV modules with a total power of 6-15 kW to connect to the Revo series hybrid inverter. Make sure that the PV modules you choose have excellent performance and reliable quality. The open-circuit voltage of the series-connected PV modules should be less than Max. PV Voltage (1000V) , and the operating voltage of PV modules should be within the MPPT voltage range (180V-850V).

Model	INV-WF-10000W-3P
Max. PV Voltage (V)	1000
MPPT Voltage Range (V)	180~850



- The voltage of PV modules is very high, which already achieve dangerous voltage range, it is essential to follow electrical safety rules when making any connections.
- DO NOT ground the PV positive and negative terminals.



- The following requirements of PV modules need to be applied for each input area.
- DO NOT ground the PV positive and (or) negative terminals.
- To save cables and reduce DC losses, it is recommended to install inverters near the PV modules.



✗ The following PV connection mode is NOT allowed!

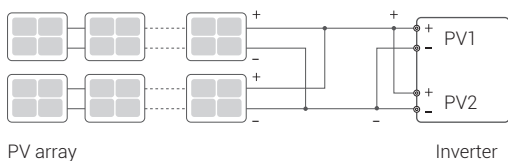

### Connection steps:

#### Step 1: Inspect PV modules

1. Measure the module array voltage with a voltmeter.
2. Check the PV+ and PV- from the PV string combiner box correctly.
3. Please make sure the impedance between the positive pole and negative pole of PV to ground should be  $M\Omega$  level.

#### Step 2: Separate DC Connector

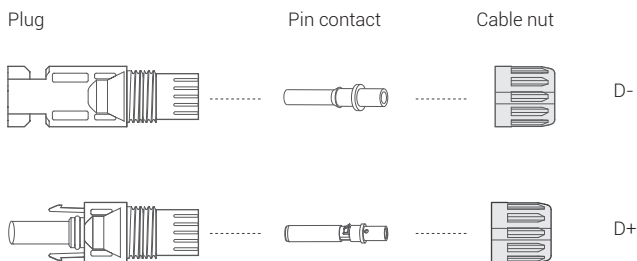

#### Step 3: Wiring

1. Connect the  $4\text{mm}^2$  wire to the cold crimp terminal.
2. Remove 10mm of insulation from the end of the wire.
3. Insert the insulator into the pin contact and clamp it with crimping pliers.



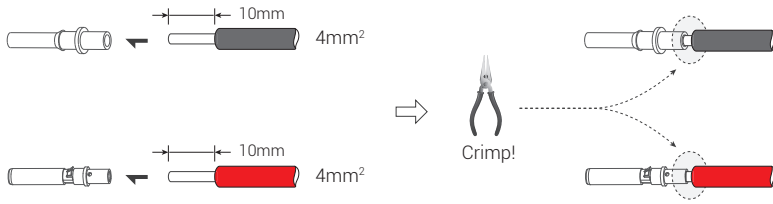

Step 4: Insert the pin contact through the nut and into the male or female plug, when a "click" is felt or heard, the pin contact assembly is properly seated. Then tighten the nut.

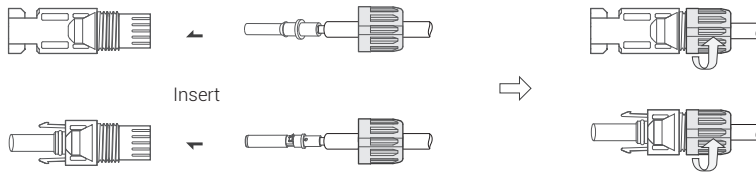

Step 5: Plug the PV connector into the corresponding interface on the inverter.

## 4.2 Grid connection

Revo series hybrid inverters are designed for three-phase grid. The voltage is 380/400V/415V, frequency is 50/60Hz. Other technical requests should comply with the requirements of the local public grid.

Model	INV-WF-8000W-1P
Cable (mm <sup>2</sup> )	4~6
Micro-breaker (A)	32

Micro-breaker should be installed between inverter and grid, and no load should be connected directly to the inverter.

Connection steps:

Step 1 : Check the grid voltage

1. Check the grid voltage and compare it with the allowed voltage range (Refer to technical data).
2. Disconnect the board from all phases and ensure that it is not reconnected.

Step 2: Remove the waterproof lid from the grid port on the inverter.

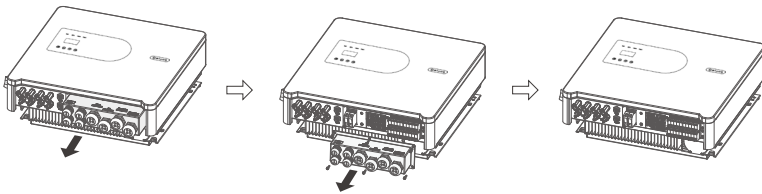

Step 3 : Make the AC wires.

1. Select the appropriate wire (Cable size: refer to Table 4-2).
2. It is recommended to keep about 60mm length of cable for crimping.
3. Remove 10mm of insulation from the end of wire.
4. Thread the end of the wire into the tubular terminal and use crimping pliers to crimp it tightly.
5. Disassemble the waterproof connector and waterproof cover and thread the cable through the waterproof connector.

Step 4 : Insert the terminals into each of the three phase grid ports (loosen or tighten the crimp terminal screws with a one-way screwdriver).

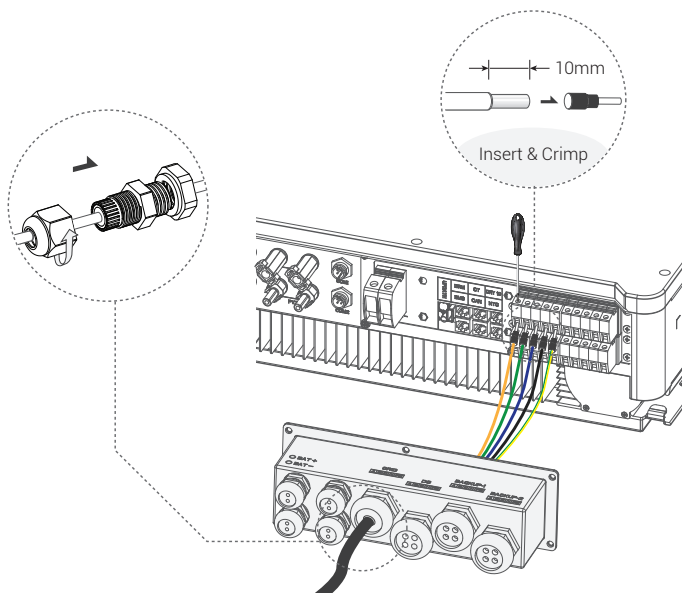

### 4.3 EPS Connection (apply to I Version and E Version only)

The REVO series hybrid inverters have both off-grid and on-grid functions. The inverters output power through the AC port when the grid is on and through the EPS port when the grid is off.

#### I Version & E Version

REVO series inverter provides two versions for customer to choose based on the local rules.

Version I applies to wiring rules that require EPS load-side ground to be isolated from grid-side ground (applies to wiring rules in Australia and New Zealand AS/NZS\_3000:2012)

Version E applies to wiring rules that require the load-side ground of the EPS to be un-isolated from the grid-side ground (applicable in most countries).

Auto & Manual

For the "E version" inverters, the EPS function can be triggered automatically or manually, depending on the user's preference.

For the "I version" inverter, the EPS function can only be triggered automatically.

If the user wants to use this function manually, an external switch needs to be installed. Please refer to the specific wiring diagram below.

For solutions, please contact our sales team.

E Version Auto

Transfer switch required.

I Version Auto

No transfer switch required.

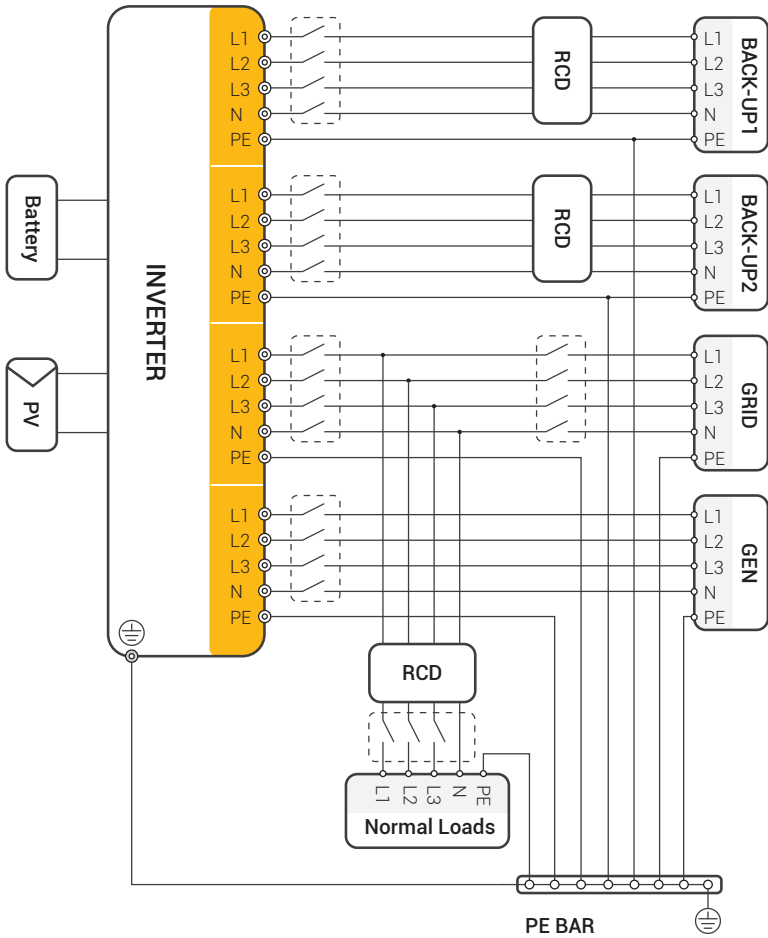

The grounding screw hole of inverter is at the lower right corner.

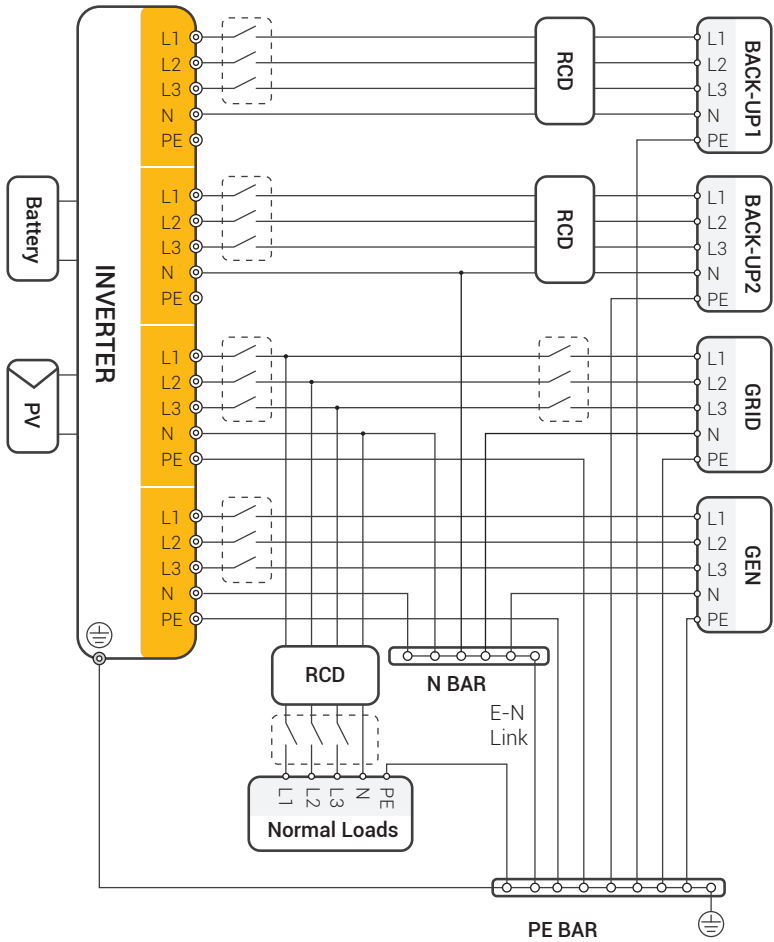

The grounding screw hole of inverter is at the lower right corner.

If you have a request for a compatible contactor, please contact our sales.



---

If local policies dictate a wiring pattern that is inconsistent with the above operating guidelines, especially for N (neutral) wire, earth and RCD, please contact us before operating! This wiring diagram is for reference only and complete electrical connections should be made in accordance with local regulations.

---

The REVO series hybrid inverters have grid-on and grid-off functions. When the grid is on, the inverter will output power through the AC port, while when the grid is off, it will output power through the BACKUP ports.

BACKUP1 for very important load, BACKUP2 for important or normal load.

When there is a power outage or no grid,

- If the battery does not report low voltage or under voltage alarm, the inverter will supply power to both BACKUP1 and BACKUP2.
- If the battery has a low voltage or under voltage alarm, the inverter only supplies power to BACKUP1.
- The total output power of the BACK-UP1 and BACK-UP2 must not exceed the rated output power.

Model	INV-WF-8000W-1P
Cable (mm <sup>2</sup> )	4~6
Micro-breaker (A)	32

Connection steps:

Step 1 : Make EPS wires.

1. Select the appropriate wire (Cable size: refer to Table 4-2).
2. It is recommended to keep about 60mm length of cable for crimping.
3. Remove 10mm of insulation from the end of wire.
4. Thread the end of the wire into the tubular terminal and use crimping pliers to crimp it tightly.

5. Disassemble the waterproof connector and waterproof cover and thread the cable through the waterproof connector.

Step 2 : Insert the terminals into the EPS port of the inverter (loosen or tighten the crimp terminal screws with a one-way screwdriver).

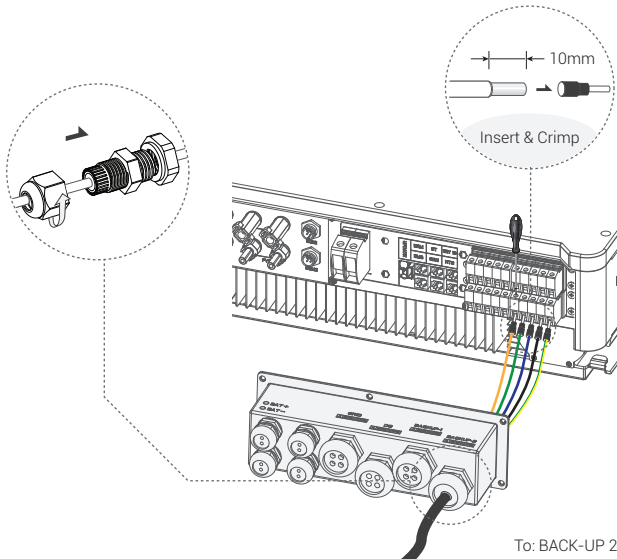
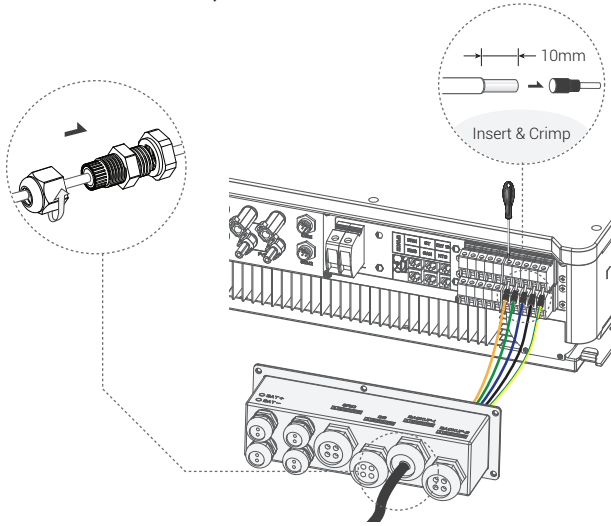



## Requirements for EPS loads

---







Make sure the rated load power of the EPS is within its rated output range, otherwise the inverter will shut down with an "overload" warning.

When an "overload" occurs, adjust the load power to ensure it is within the EPS output power range before turning on the inverter.

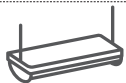

For non-linear loads, make sure that the surge power should be within the output power range of the EPS.

---

The following table shows some common feasible loads for your reference.

Type	Power		Common equipment	
	Start	Rated		
Resistive load	R1	R1	 Incandescent lamp	 TV
Capacitive load	R2	R1.5	 Fluorescent lamp	
Inductive load	R3~5	R2	 Fan	 Fridge

For example:

Equipment	Power	
	Start	Rated
 Incandescent lamp : 100W	100VA (W)	100VA (W)
 Fluorescent lamp: 40W	80VA (W)	60VA (W)
 Fridge: 150W	450~750VA (W)	300VA (W)

#### 4.4 Battery Connection

The charge/discharge system of Revo series hybrid inverters is designed for high voltage lithium batteries.

Before selecting a battery, please note that the battery communication should be compatible with the Revo series hybrid inverter.

##### Battery breaker

Before connecting to the battery, install a non-polarized DC circuit breaker to ensure that the inverter can be safely disconnected during maintenance.

Model	INV-WF-10000W-3P
Voltage	Nominal voltage of DC breaker should be larger than maximum voltage of battery
Current (A)	60

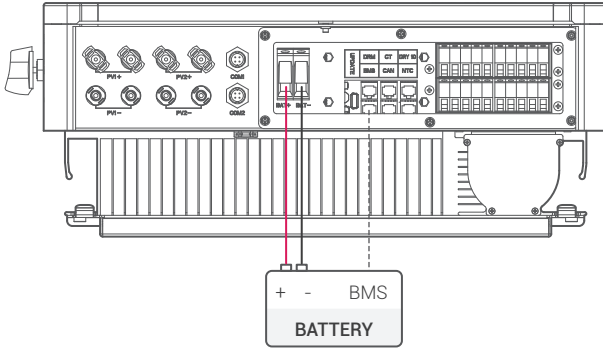

### BMS PIN Defination

The communication interface between the inverter and the battery is RJ45, and its communication protocol standard is or CAN.

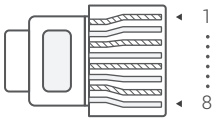

PIN	1	2	3	4	5	6	7	8
BMS	RS485_ WIFIA	RS485_ WIFIB	×	BMS_CANH	BMS_CANL	GND	BMS_485A	BMS_485B



The battery communication can only work when the battery BMS is compatible with the inverter.

Battery connection steps:

Step 1: Select the 10mm<sup>2</sup> wire and remove 15mm of insulation from the end of wire.

Step 2: Thread the end of the wire into the tubular terminal and use crimping pliers to crimp it tightly.

Step 3: Disassemble the waterproof connector and pass the cable through the waterproof connector.

Step 4: Insert the terminals into battery ports on the inverter.

Step 5: Assemble waterproof connectors and waterproof cover.

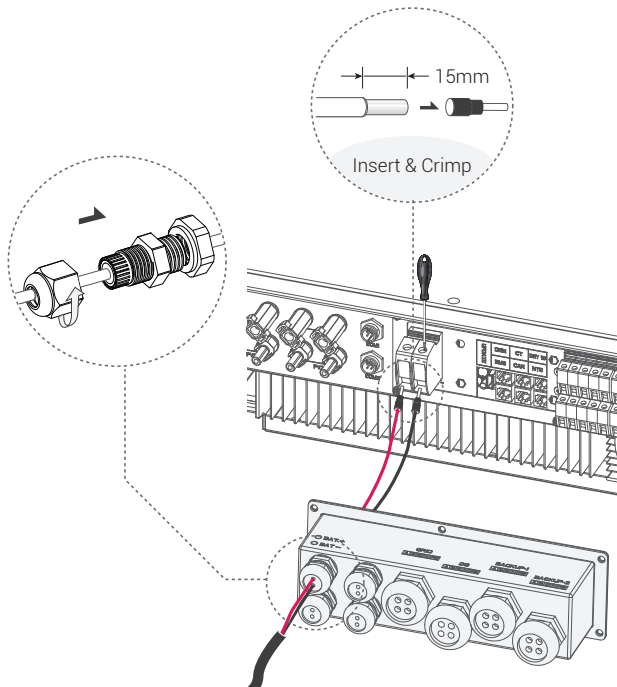

## 4.5 CT Connection and Phase instruction

CT is used for monitoring the power usage for entire house, and send the data to the inverter to achieve anti-reflux function (to prevent the power back flow to the grid). The inverter can also use the data from a meter to achieve the anti-reflux function.

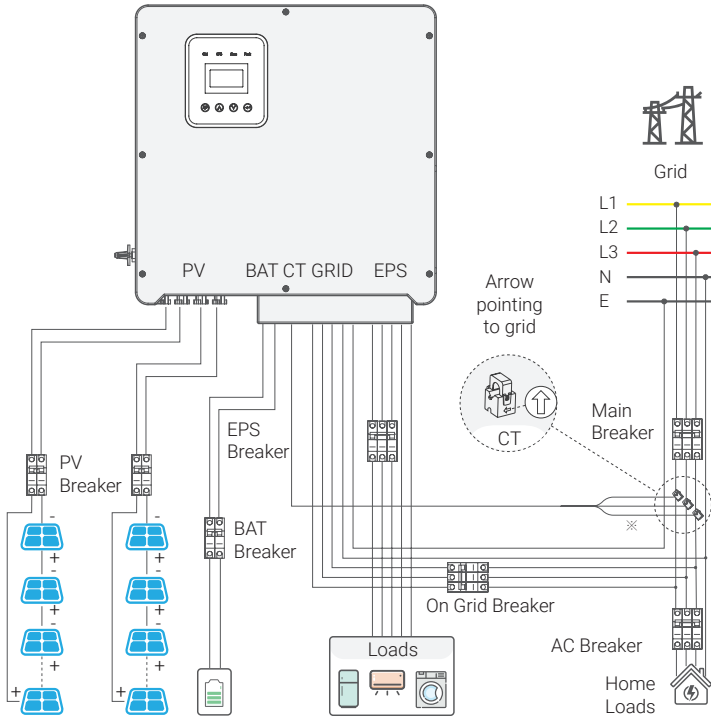

The CT arrow points to the grid, otherwise the inverter will display wrong data or the machine will not work properly.

Pay attention to phase sequence when wiring. With incorrect phase sequence, the inverter will not operate properly.

※ *The three wires of yellow, green, and red in CT correspond respectively to the three phases of the power grid's line sequence, which are A, B, and C.*

CT connection steps:

Step 1: Disassembly of waterproof connector and waterproof cover.

Step 2: Prepare a communication cable (without sheath) and pass the cable through the waterproof connector.

Step 3: Insert RJ45 end of the CT cable into the CT port of the inverter.

Step 4: Assemble waterproof connectors and waterproof cover.

DRM	CT	Dry Contact
BMS-485		
BMS-CAN	Parallel	NTC

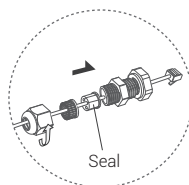

The seal is for waterproofing.  
Please make sure it is put back in.

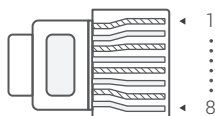
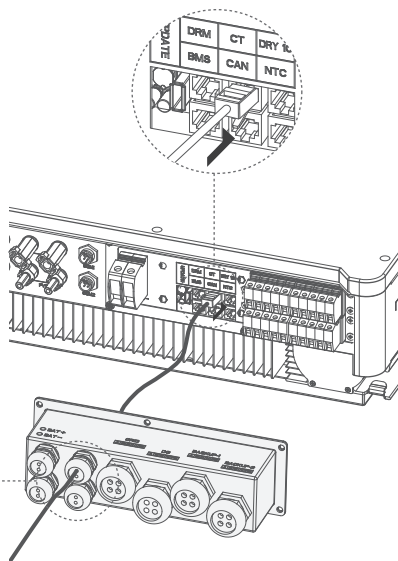

PIN(CT)	1	2	3	4	5	6	7	8
Definition	IGRID_	IGRID_	IGRID_	IGRID_	IGRID_	IGRID_	RS485_	RS485_
	AP_I	AN_I	BN_I	CP_I	CN_I	BP_I	METERA	METERB

**NOTE:** PIN 7 and PIN 8 can be use to connect to a smart meter, the model of the meter is DTSU666, DSSU666 from CHNT or ADL400/C from ACREL, you can ask the distributor for more information.

## 4.6 DRM Connection

The DRM supports several demand response modes by transmitting control signals as shown below.

EUROPEAN general (50549) DRM demand: DRM ports PIN5 and PIN6 are connected with 0 charge/discharge power.

Germany (4105) DRM demand:

DRM0: DRM ports PIN5 and PIN6 are connected with 0 charge/discharge power.

DRM5: DRM ports PIN1 and PIN5 are connected with  $\leq 30\%$  charge/discharge power.

DRM6: DRM ports PIN2 and PIN5 are connected with  $\leq 60\%$  charge/discharge power.

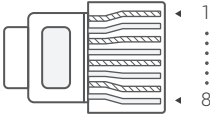

PIN(DRM)	1	2	3	4	5	6	7	8
Definition	DRM1/5	DRM2/6	DRM3/7	DRM4/8	+5V	DRM0	GND	GND

DRM connection steps:

Please refer to CT steps for DRM connection. Please kindly note that the definition of PIN and the location of the port will be slightly different.

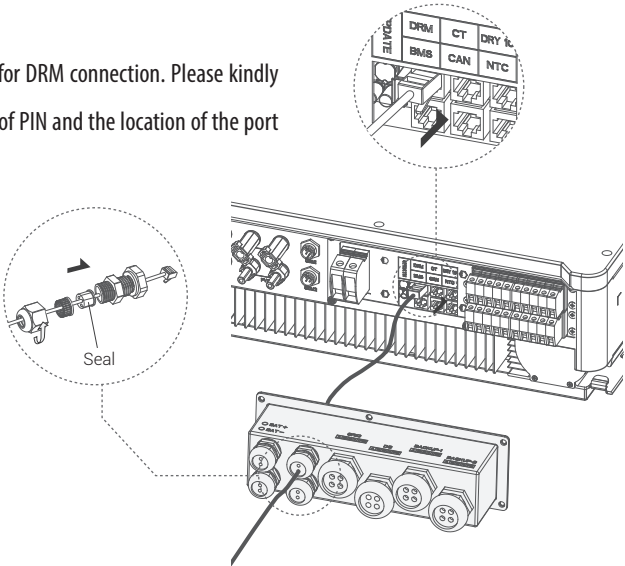

The seal is for waterproofing. Please make sure it is put back in.

## 4.7 WiFi Connection (optional)

Revo series hybrid inverters offer a WiFi port that allows data to be collected from the inverter and transmitted to a monitoring website via WiFi. Purchase this WiFi adaptor from the supplier if needed.

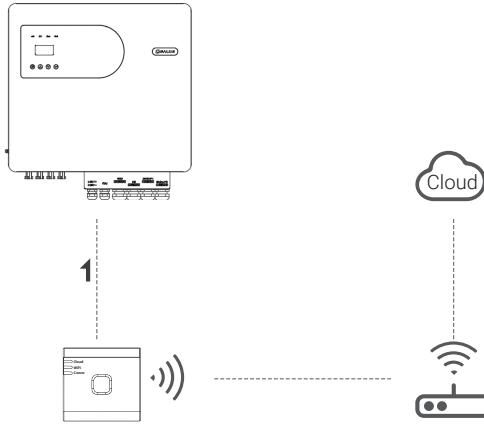

WiFi connection steps:

Step 1: Assemble WiFi adaptor to COM2 (WiFi) port at the bottom of the inverter.

Step 2: Establish the connection between the inverter and the router.

Step 3: Create a user account online. (Please check the “WiFi adaptor user manual” for more details).

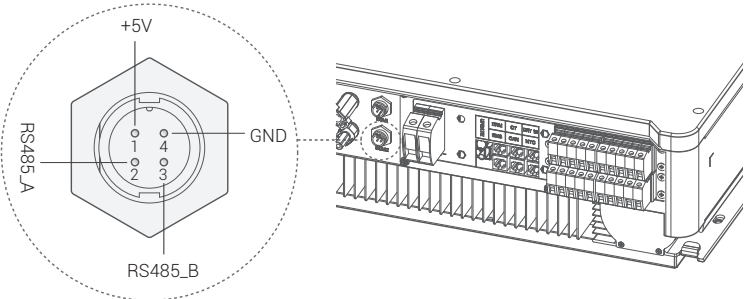



## 4.8 Inverter Manipulation

Start inverter after checking all the following steps:

- ✓ Make sure the inverter is fixed well on the wall.
- ✓ Make sure all DC wiring and AC wiring is complete.
- ✓ Make sure the meter/CT is well connected.
- ✓ Make sure the battery is well connected.
- ✓ Make sure the external load contactor is well connected.
- ✓ (If needed) Turn on the AC switch and EPS switch.  
Turn on the PV/DC switch and the battery switch.

Check the inverter:

Step 1: Check the status of the indicators and the LCD screen. The screen should display the main interface.



---

If the light on the left is not green, please check the following three items:

- All the connections are correct.
- All the external breakers are switched on.
- The DC switch on the inverter is in the "ON" position.

---

Step 2: If it is the first time to start, please follow this procedure. For specific settings, please refer to Section 5 (Setting).

Step 3: Set up the wifi according to the wifi user manual.

Step 4: Perform "self-test". (for Italy only). Self-test according to CEI 0-21 (only for Italy).

The self-test is only used for inverters that are operated and commissioned in Italy.

According to the Italian standard requirements, all inverters entering the utility grid are equipped with a self-test in accordance with CEI 0-21. During the self-test, the inverters are continuously checked for protection response times and values for overvoltage, undervoltage, overfrequency and underfrequency.

# 5 Setting

## 5.1 Control Panel

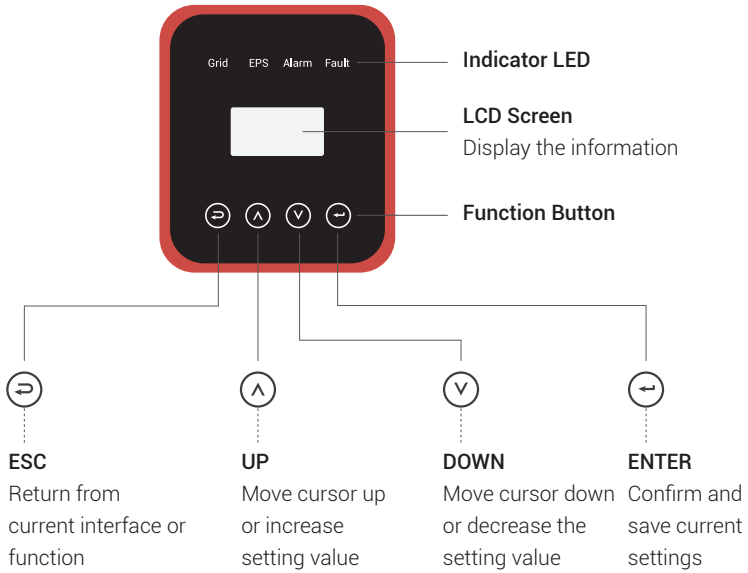

## 5.2 Instructions for LED Indicator

	<b>Grid (Green)</b>	<b>EPS (Green)</b>	<b>Alarm (Yellow)</b>	<b>Fault (RED)</b>
Initialization	OFF	OFF	OFF	OFF
Stand-by	OFF	OFF	OFF	OFF
On-Grid	ON	-	-	-
Off-Grid	OFF	ON	OFF	OFF
Bypass	ON	OFF	OFF	OFF
Fault	OFF	OFF	OFF	ON

## 5.3 Instructions for the use of three modes

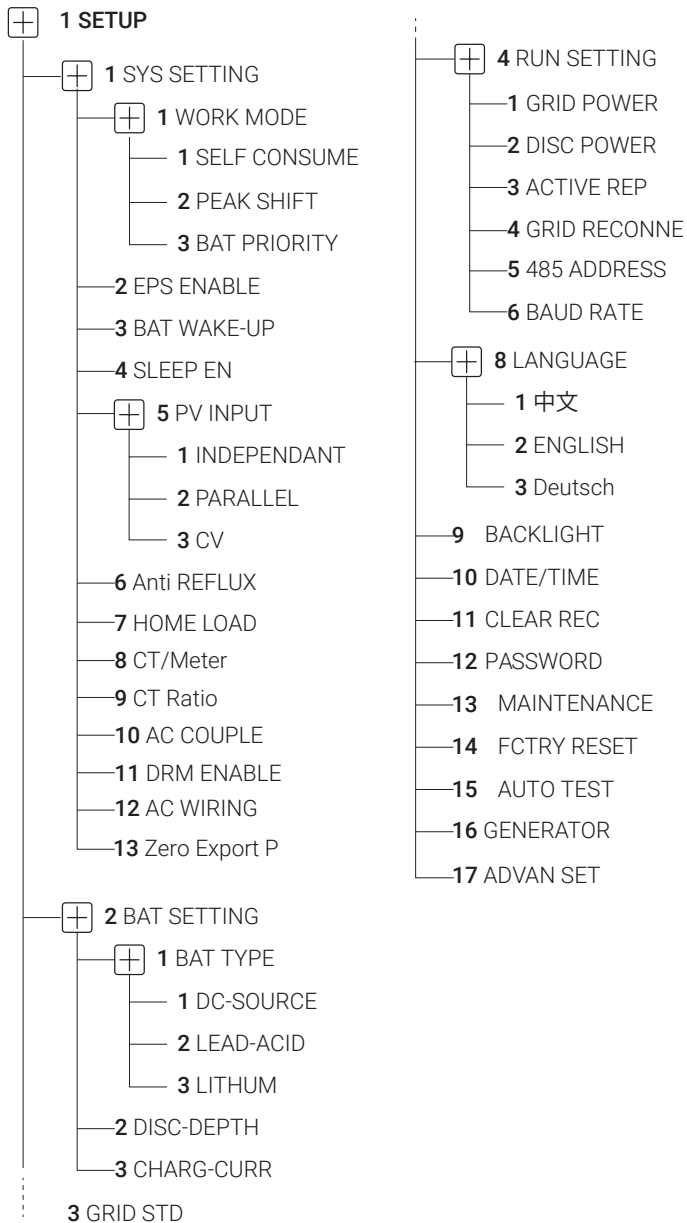

- +** **2 INQUIRE**
  - 1 INV MODULE
  - 2 MODULE SN
  - 3 FIRMWARE
  - 4 RECORD
  - 5 DIAGNOSE

- +** **3 STATISTIC**
  - 1 E-TODAY
  - 2 E-MONTH
  - 3 E-YEAR
  - 4 E-TOTAL

For example: Before selecting the mode, you can set it up according to the local power grid, PV input mode and battery type.

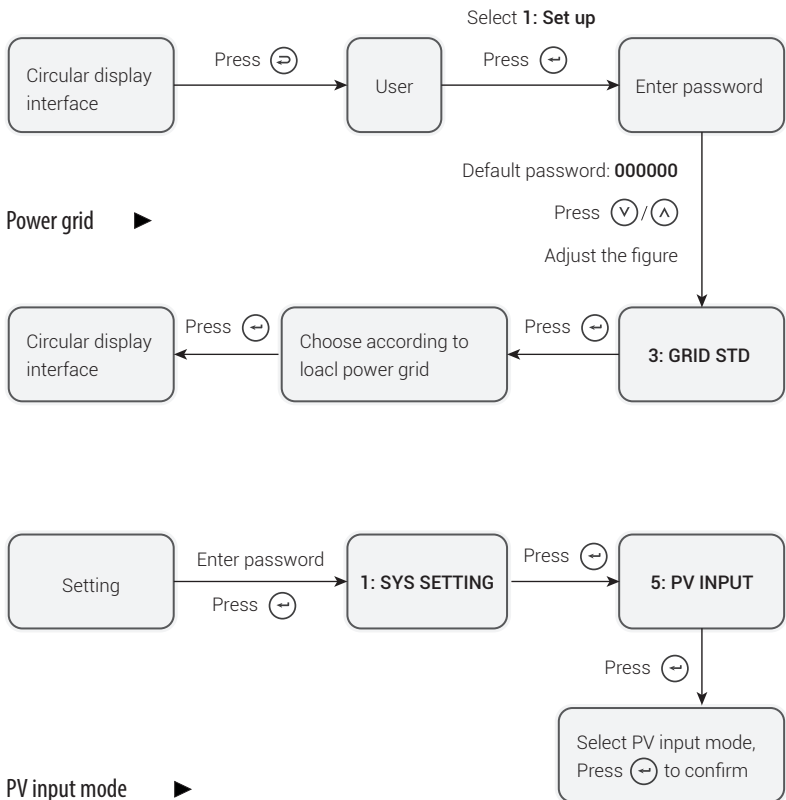

## Battery parameters ▶

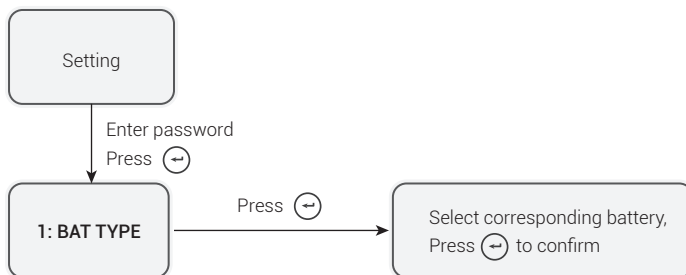

## 6 LCD Operation

### 6.1 LCD Interface

#### 6.1.1 Events information

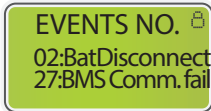

- Numbers represent error codes and text is events message.
- Refer to Chapter 7 for contents.

NOTE: When  appears in the upper right corner of the screen, you cannot turn the page, you need to press  to unlock it first.

#### 6.1.2 System setting 1

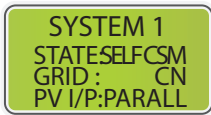

- State: Set the working mode of the whole inverter.  
Including: SELF CONSUME, PEAK SHIFT and BAT PRIORITY.

Refer to Chapter 2.3 for specific contents.

- Grid standard: Displays the actual set grid standard.
- PV input mode: The displayed value is the set value for the PV input type, including INDEPENDANT, PARALLEL, CV. See section 6.2.4.7 for settings and explanations.

#### 6.1.3 System setting 2

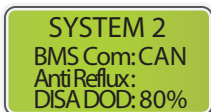

- BMS Com: Battery Management System communication mode, Including CAN.
- Anti-Reflux :Indicates whether the inverter is not allowed to generate power to the grid, including DISABLE, ENABLE. See section 6.2.4.8 for settings and explanations.
- DOD: The depth of discharge of the battery. When the battery is discharged beyond this setting, the inverter will report a low or undervoltage alarm and the battery stops discharging.

### 6.1.4 System setting 3

```
SYSTEM 3
EPSEnable: ENAB
CT/Meter: CT
```

- EPS ENABLE: Enables the battery to supply power to the load when the grid and PV are off, which is enabled by default.

### 6.1.5 PV1 Input display interface

```
PV1 INPUT
VOLT: 0.0V
CURR: 0.00A
POWER: 0W
```

- PV1 input real-time voltage
- PV1 input real-time current
- PV1 input real-time power

### 6.1.6 PV2 Input display interface

```
PV2 INPUT
VOLT: 0.0V
CURR: 0.00A
POWER: 0W
```

- PV2 input real-time voltage
- PV2 input real-time current
- PV2 input real-time power

### 6.1.7 DC Voltage interface

```
DC VOLTAGE
BUS+: 0.0V
BUS-: 0.0V
```

- BUS+: Real-time voltage of bus capacitor of the inverter
- BUS-: Real-time voltage of bus capacitor of the inverter

### 6.1.8 Battery interface

```
BATTERY
VOLT: 0.0V
CURR: 0.0A
STA: C D F
```

- Battery real-time voltage
- Battery real-time current
- STA: Battery status

C : Indicates that the battery is chargeable (from the BMS).

D : Indicates that the battery can be discharged (from BMS).

F : The battery requires forced charging (from BMS).

### 6.1.9 Battery information interface

BATTERY INFO	
TYPE:	Lithium
TEMP:	26°C
SOC:	30%

- TYPE: Battery type:(lead-acid, lithium battery)
- TEMP: Battery temperature
- SOC: Percentage of battery capacity from the BMS

### 6.1.10 Battery current interface

BMS PRMETER	
CHARVOL:	0.0V
CHARGE:	0A
DISCHA:	0A

- CHAR VOL: Max. charging voltage requested by the battery BMS
- CHARGE: Max. charging current requested by the battery BMS
- DISCHA: Max. discharging current requested by the battery BMS

### 6.1.11 Grid-connected

GRID FREQ	
GRID FREQ:	0.00Hz
U:	0.0V 0.0A
V:	0.0V 0.0A
W:	0.0V 0.0A

- GRID FREQ: Grid real-time frequency.
  - CT: Current transformer
- U: Grid-phase U real-time voltage | CT real-time current
  - V: Grid-phase V real-time voltage | CT real-time current
  - W: Grid-phase W real-time voltage | CT real-time current

### 6.1.12 INV

INV FREQ	
INV FREQ:	0.00Hz
U:	0.0V 0.0A
V:	0.0V 0.0A
W:	0.0V 0.0A

- INV FREQ: Grid real-time frequency
  - U: INV -phase U real-time voltage | INV -phase U real-time current
- V: INV -phase V real-time voltage | INV -phase V real-time current
  - W: INV -phase W real-time voltage | INV -phase W real-time current



### 6.1.13 LOAD

LOAD:	
U: 0.0V	0.0A
V: 0.0V	0.0A
W: 0.0V	0.0A

Synonymy: BACK-UP/EPS/LOAD

- U: Load-phase U real-time voltage | Load-phase U real-time current
- V: Load -phase V real-time voltage | Load-phase V real-time current
- W: Load -phase W real-time voltage | Load-phase W real-time current

### 6.1.14 INV POWER

POWER	
INV U:	0.0W
INV V:	0.0W
INV W:	0.0W

- INV U: INV -phase U power.
- INV V: INV -phase V power.
- INV W: INV -phase W power

### 6.1.15 GRID POWER

POWER	
GRID U:	0.0W
GRID V:	0.0W
GRID W:	0.0W

The CT arrow points to the power grid. The discharge from the inverter to the grid is "+", and the opposite is "-".

- GRID: GRID -phase U power
- GRID: GRID -phase V power
- GRID: GRID -phase W power

### 6.1.16 EPS LOAD POWER

EPS LOAD POWER	
U:	0W0%
V:	0W0%
W:	0W0%

- U : Load-phase U power percentage
- V : Load-phase V power percentage
- W: Load-phase W power percentage

### 6.1.17 POWER

POWER	
PV:	0W
BAT:	0W
HOMELOAD:	0W

- PV : PV power
- BAT: Battery power
- HOMELOAD: if you have a load connected to the mains port, you can see its load power.

### 6.1.18 Temperature

TEMPERATURE	
INVER:	0°C
DCDC:	0°C
INSIDE:	0°C

- INVER: DC/AC temperature
- DCDC: DC/DC temperature
- INSIDE: Internal ambient temperature

### 6.1.19 State

STATE	
SYS:	STANDBY
INV:	STANDBY
DCDC:	STANDBY

- SYS: Display complete inverter status information, Including: Initialization, Standby, PV connected to grid, Battery connected to Grid, Hybrid power supply, Fault, Service ,Self -check, Off grid, grid, INV to PFC , Charging enable, Discharge enable, Force charge enable, etc.
- INV: Displays the inverter status information.
- DCDC: Displays charging and discharging status information.

## 6.2 Setting

### 6.2.1 State



- SETUP: Press  $\leftarrow$  to enter user settings interface.
- INQUIRE: Query inverter model, serial number, software version.
- STATISTIC: View inverter operating statistics.

### 6.2.2 Set password

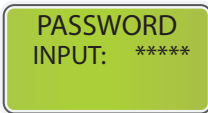

- Enter the password required for setting. The default password is "00000".
- Press  $\wedge$  or  $\vee$  to adjust the number, press  $\leftarrow$  to move the cursor forward, and press  $\rightarrow$  move the cursor backward.

### 6.2.3 Setup

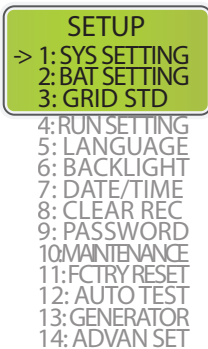

- This interface is used for various information inquiry menus.
- Press  $\wedge$ / $\vee$  to select the corresponding option.
- Press  $\leftarrow$  to enter the selected menu.
- Press  $\rightarrow$  to return to the user interface. (Refer to 6.2.1).
- There are 16 options in total.

### 6.2.4.1 System setting

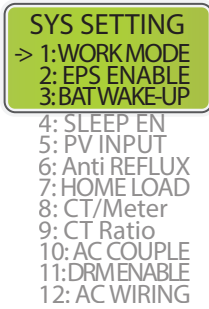

- This interface is used to access system information.
- Press  $\uparrow$ / $\downarrow$  to select corresponding option.
- Press  $\leftarrow$  to enter the selected menu.
- Press  $\rightarrow$  to return to the setting interface.
- There are 12 options in total.

### 6.2.4.2 Work mode

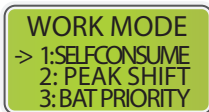

- This interface is used to select the working mode.
- Press  $\rightarrow$  to return to setting interface.

### 6.2.4.3 Peak shift work time (Please see the content on P063)

#### 6.2.4.4 EPS enable

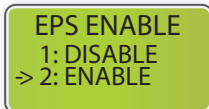

- When the Grid and PV are powered OFF, enable the battery to supply power to the load, default option is enable.

#### 6.2.4.5 Battery wake-up

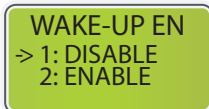

- When the battery is low and the battery relay has been disconnected, the inverter will send a signal through the

BMS to the battery force-suck relay and the inverter will charge.

- The default option is disabled. (Supported by partial lithium batteries)
- If you want to use this function, please consult your dealer for supported battery brands. Use only when the battery is too low.

### 6.2.4.3 Peak shift work time

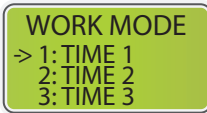
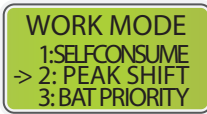

- This interface is used to select the working mode.
- Press  $\odot$  to return to setting interface.
- Select the peak shift mode, you also need to set the charge and discharge time.
- It's allowed to set 3 charging and discharging periods.
- When setting the time, ensure that the time of the inverter is the local time.
- Press  $\leftarrow$  to enter the next menu.
- This parameter is set to one day. If the specified time conflicts, the first time is executed as the primary time. If the three time ranges do not conflict, the three time ranges are executed sequentially.
- This interface is used to adjust the timing of battery charging and discharging during peak periods.

### 6.2.4.6 SLEEP EN

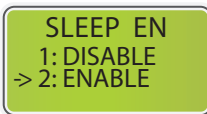

- Sleep enablement allows.

### 6.2.4.7 PV input mode



Setup of PV Input mode.

- End users please select INDEPENDENT mode.

- PARALLEL & CV : for testing purposes only.

The factory setting by default is Independent, When parallel input is set to be Independent mode, PV power will be imbalanced.

#### 6.2.4.8 Anti Reflux

ANTI REFLUX  
> 1: DISABLE  
2: ENABLE

- Anti- Reflux: Whether the inverter is not allowed to supply power to the grid.
- The default option is disable.

#### 6.2.4.9 Home load

HOME LOAD  
> 1: DISABLE  
2: ENABLE

- When set to "ENABLE", if you have a load connected to the mains port, you can see its load power.

#### 6.2.4.10 CT/Meter

CT/METER  
> 1: CT  
2: CHINT  
3: Acrel

- Manually select whether to use CT or electricity meters.

#### 6.2.4.11 CT Ratio

CT RATIO  
INPUT:01000:1

- CT proportional parameters. Depending on the actual CT ratio parameter, the factory default is 1000:1.

#### 6.2.4.12 AC Couple

AC COUPLE  
> 1: DISABLE  
2: ENABLE

- Manually select whether AC coupling is enabled.

#### 6.2.4.13 DRM ENABLE

DRM ENABLE  
> 1: DISABLE  
2: ENABLE

- Manually select whether DRM is enabled or not.

#### 6.2.4.14 AC WIRING

AC WIRING  
> 1: TN-S  
2: TN-C

- Manually select the wiring method
- TN-S: TN-S stands for three-phase five-wire
- TN-C: TN-C stands for three-phase four-wire

## 6.2.5 Bat setting

### 6.2.5.1 Bat setting

BAT SETTING  
> 1: BAT TYPE  
2: DISC-DEPTH  
3: CHARG-CURR

- This interface is the battery parameters menu.
- Press  $\uparrow/\downarrow$  to select corresponding option;
- Press  $\leftarrow$  to enter the selected menu;
- Press  $\rightarrow$  to return to setting interface.

### 6.2.5.2 Bat type

BAT TYPE  
1: DC-SOURCE  
> 2: LEAD-ACID  
3: Lithium

- This interface is used to select battery type.
- DC-SOURCE is used for R&D testing and is disabled for customers.
- Select the LEAD-ACID , press  $\leftarrow$  to enter LEAD-ACID interface;

### 6.2.5.3 Lead-acid battery parameter

LEAD-ACID  
> 1: CHARG-VOLT  
2: CV Charge V  
3: BAT ENDVOLT  
4: BAT OVP  
5: BAT CAP

CHARGE VOLT  
INPUT: 135  
UNIT: V

ABSORPTION V  
INPUT: 110  
UNIT: V

BAT END VOLT  
INPUT: 108  
UNIT: V

- This interface is LEAD-ACID battery parameters menu.
- Press  $\uparrow/\downarrow$  to select corresponding option;
- Press  $\leftarrow$  to enter the selected menu;
- This interface is used to set the lead acid battery charging voltage. (The input value ranges from 135 to 600)
- This interface is used to set up lead-acid Battery constant voltage charging voltage.(The input value ranges from 110 to 499)
- This interface is used to set the lead-acid battery discharging voltage.(The input value ranges from 108 to 600)
- Cut-off discharge voltage, as recommended by the battery manufacturer.

BAT OVP  
INPUT: 141  
UNIT: V

- This interface is used to set the lead acid battery charge protection voltage. (The input value ranges from 141 to 600)
- Charge protection voltage, as recommended by the battery manufacturer.

BAT CAP  
INPUT: 0450  
UNIT: AH

- This interface is used to set the lead acid battery capacity. It is related to the input power. (The input value ranges from 50 to 1000)
- The battery capacity setting will affect the maximum charging current. For example, if it is set to 100Ah, the maximum charging current will be  $100A \times 0.2 = 20A$ .

#### 6.2.5.4 Lithun battery

BAT TYPE  
1: DC-SOURCE  
2: LEAD-ACID  
3: Lithium

- Lithium batteries have a voltage range of 125V to 600V.



## 6.2.6 Grid standard



4: UK  
 5: PK  
 6: KR  
 7: PHI  
 8: CN  
 9: US-CA  
 10: THAIL  
 11: ZA  
 12: CUSTOM  
 13: POL  
 14: EN50549  
 15: GER-VDE4105  
 16: JPN  
 17: ITA  
 18: SLO  
 19: CZE  
 20: SWE  
 21: HU  
 22: SK  
 23: AT  
 24: BE

- This interface is used to select Grid standard.
- Press  $\wedge$ / $\vee$  to select the corresponding option.
- Press  $\leftarrow$  to confirm.

1: AU-Australia	240V/415V 50Hz
2: AU-W-Western Australia	240V/415V 50Hz
3: NZ-New Zealand	240V/415V 50Hz
4: UK-United Kingdom	230V 50Hz
5: PK	230V 50Hz
6: KR-Korea	220V/380V 60Hz
7: PHI-Philippines	110V/220V 60Hz
8: CN-China	220V/380V 50Hz
9: US-CA-America	120V/240V 208V/240V 60Hz
10: THAIL	220/380V 50Hz
11: ZA-South Africa	230V 50Hz
12: CUSTOM-User defined	-
13: POL	230V/380V 50Hz
14: EN50549	217V/220V/240V 380V/400V 50HZ/60Hz
15: GER-VDE4105-Germany	230V/380V 50Hz
16: Japan	110V/190V/60Hz
17: Italy	230V/380V/50Hz
18: Slovenia	230V/380V/50Hz
19: Czech Republic	230V/380V/50Hz
20: Sweden	230V/380V/50Hz
21: Hungary	230V/380V/50Hz
22: Slovakia	230V/380V/50Hz
23: Austria	230V/400V/50Hz
24: Belgium	230V/400V/50Hz

If none of the above options are available, please consult your dealer.

## 6.2.7 Run setting

### 6.2.7.1 Run setting



- This interface is run setting menu.
- Press  $\uparrow$ / $\downarrow$  to select the corresponding option.
- Press  $\rightarrow$  to enter the selected menu.
- To modify the factory default settings, please contact your dealer.

### 6.2.7.2 Grid power

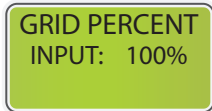

- The input value is the power percent of the grid.

### 6.2.7.3 Discharge power

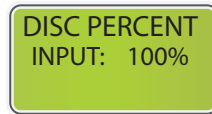

- The input value is the power percent of battery discharge.

### 6.2.7.4 ACTIVE TYPE

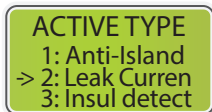

- This interface is used to select run setting.
- Factory default Settings. Please consult the distributor for modification.

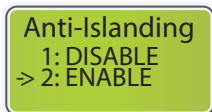

- Anti-Island enable.

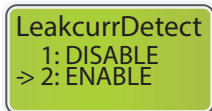

- Leak Current Detection enable

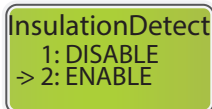

- Manually select whether insulation detection is enabled.

### 6.2.7.5 Grid Reconnect Time



- Grid reconnection time, according to each country-specific standard

### 6.2.8 Language



This interface is used to select language.

### 6.2.9 Backlight

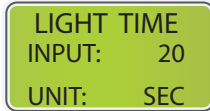

This interface is used to set backlight duration of LCD.

### 6.2.10 Date/time

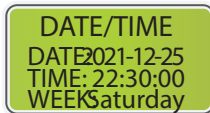

This interface is used to set date and time.

### 6.2.11 Clear REC



This interface is used to clear operation history.

### 6.2.12 Password

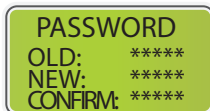

This interface is used to set password.

### 6.2.13 Maintenance



This interface is used to enter maintenance. The default password is 99999.

### 6.2.14 Factory reset



This interface is used to reset the inverter.

### 6.2.15 AUTO TEST

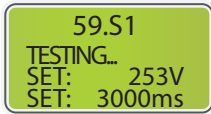

Italian safety self-test function.

### 6.2.18 Generator Setting

The Generator setting page can be accessed from the following steps in the screen:

USER->1. SETUP->15. Generator

### 6.2.18.1 Setting

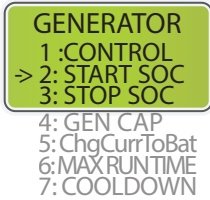

This interface shows Generator setting.

1. Refer to 6.2.18.2 CONTROL.
2. When the SOC of battery is lower than the set point, the Generator dry contact is enabled and Generator Manual operation is disabled, the connected Generator will be started.
3. When the SOC of battery is lower than the set point, the Generator dry contact is enabled and Generator Manual operation is disabled, the connected Generator will be started.
4. Rated power of Generator.
5. It indicates the maximum current that the inverter charges the battery from Generator.
6. It indicates the longest time Generator can run in one day, when time is up, the Generator will be turned off. The value 240 means 24 hours in which state the Generator will not be shut down all the time. The unit is 0.1 hour.
7. It indicates the waiting time of the Generator to restart after it has reached the running time. The unit is 0.1 hour.

### 6.2.18.2 CONTROL

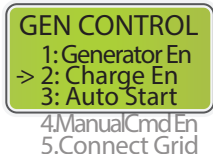

This interface shows Generator CONTRL.

1. Enable control of the Generator function.
2. Generator Charge Enable control
3. If this function is enabled, the dry contact of the generator automatically draws and closes when the SOC of the battery reaches the SOC setting value of the generator startup, thus controlling the automatic startup of the generator. If this function is disabled, manually start the generator.
4. When enabled, the generator can be manually started.
5. Connect the diesel Generator to the grid input port.

### 6.2.18.3 START SOC



This interface is used to set the minimum battery capacity when starting the generator.

### 6.2.18.4 STOP SOC

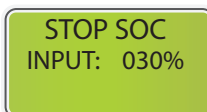

This interface is used to set the maximum battery capacity when the generator is turned off ( START SOC < STOP SOC).

### 6.2.18.5 GEN CAP



This interface is used to set the diesel generator power.

### 6.2.18.6 ChgCurrToBAT

```
ChgCurrToBAT
INPUT: 030
UNIT: A
```

This interface is used to set the battery charging current when the generator is used.

### 6.2.18.7 MAX RUN TIME

```
MAX RUN TIME
INPUT: 10.0
UNIT: hours
```

This interface is used to set the maximum running time of the generator.

### 6.2.18.8 COOLDOWN

```
COOL DOWN TIME
INPUT: 02.0
UNIT: hours
```

This interface is used to set the cooling time.

## 6.3 Advan set

### 6.3.1.1 Advan set

```
ADVAN SET
> 1: Mode Set
2: Advan Ctrl
3: TOU Set
4: GridPowerLim
```

Advanced mode can only be used in spontaneous self-use mode.

### 6.3.1.2 Mode Set

```
MODE SET
> 1: Disable
2: Load First
3: Sell First
4: BatChgFirst
```

- Disable(Disable this option).
- Load First(The PV power supplies power to the load first).
- Sell First(PV power is preferentially sold).
- BatChgFirst(The PV power preferentially charges the battery).

### 6.3.2.1 Advan Ctrl



This interface is used to select enable Settings.

- Press  $\uparrow/\downarrow$  to select corresponding option.
- Press  $\rightarrow$  to enter the selected menu.
- Press  $\leftarrow$  to return to the Settings screen.

### 6.3.2.2 Grid Chg En



The grid can charge the batteries.

### 6.3.2.3 TIME OF USE



The battery time range operation function is enabled.

### 6.3.2.4 GridLimitEn



Power grid limited enable.



### 6.3.3 TOU Set

TIME OF USE  
> 1: Slot1  
2: Slot2  
3: Slot3  
4: Slot4  
5: Slot5  
6: Slot6

SLOT1  
> 1: Slot1  
2: GridChg1

SLOT2  
> 1: Slot2  
2: GridChg2

SLOT3  
> 1: Slot3  
2: GridChg3

Battery TOU enabled time range.

- The maximum allowable setting time is 24 hour (one day), It is allowed to set 6 different charging and discharging states within 24 hour(time1 twice,time2 twice,time3 twice), The inverter runs repeatedly every day according to the set time.
- The inverter executes according to the settings of time1, time2 and time3 in the order of time. Different time periods do not overlap.

Only three time periods are listed here, and the Settings for the remaining three pages are the same.

### 6.3.4 GridPowerLim

POWER  
INPUT: +00.0  
UNIT:  
kW

Grid limited power Settings.

## 6.4 Inquire

### 6.4.1 Inquire

INQUIRE  
> 1: INV MODULE  
2: MODULE SN  
3: FIRMWARE  
4: RECORD  
5: DIAGNOSE

- Press  $\uparrow$ / $\downarrow$  to select corresponding option;
- Press  $\leftarrow$  to enter the selected menu.
- Press  $\rightarrow$  to return to other interface.

### 6.4.2 INV module

MODEL  
12K

This interface displays inverter model.

### 6.4.3 Module SN

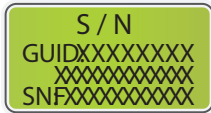

This interface displays module SN.

### 6.4.4 Firmware

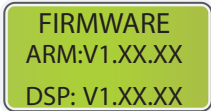

This interface displays software version.

### 6.4.5 Running records



This interface displays running recorders.

### 6.4.6 Diagnose

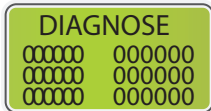

For internal use in the factory.

## 6.5 Statistic

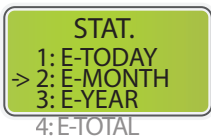

This interface displays inverter operation statistics.

- 1: Displays statistic for the day (kWh).
- 2: Displays statistic for the month (kWh).
- 3: Displays statistic for the year (kWh).
- 4: Displays statistic of the inverter (kWh).

NOTE:

1. E-TODAY/MONTH/YEAR/TOTAL→INPUT→PV/GRID(Consume)/BATD(Battery discharge)→OUTPUT→BatC(Battery charge)/GRID(Generation)/CNSUM(Load consume)
2. If the inverter is shut down before 24:00 of the day, the statistics of the day will not be stored.

## 7 Fault diagnosis and solutions

When you encounter the following problems, please refer to the Solutions below, and contact the local distributor if the problem remains unsolved. The following table lists some of the basic problems that may occur during the actual operation as well as their corresponding basic solutions.

---

<b>Codes:</b>	00	<b>Solutions:</b>
<b>Content:</b>	DischgOverCur	
<b>Explanation:</b>	The discharge current set exceeds the current uploaded by the BMS to the inverter.	
		Reduce the discharge current

---

<b>Codes:</b>	01	<b>Solutions:</b>
<b>Content:</b>	Over Load	
<b>Explanation:</b>	The load of the belt exceeds the rated power of the inverter	
		Reduce the load power.

---

<b>Codes:</b>	02	<b>Solutions:</b>
<b>Content:</b>	BatDisconnect	
<b>Explanation:</b>	The battery and battery communication cable are not connected to the specified place in the inverter.	
		Check whether the battery cable is connected to the battery communication cable and whether the battery is powered on.

---

---

<b>Codes:</b>	03	<b>Solutions:</b>
<b>Content:</b>	Bat Under Vol	
<b>Explanation:</b>	Charge the battery so that it exceeds the battery low voltage protection level.	
The battery voltage is below the normal range.		

---



---

<b>Codes:</b>	04	<b>Solutions:</b>
<b>Content:</b>	Bat Low capacity	
<b>Explanation:</b>	Charge the battery so that its SOC value is greater than the battery's protection value plus the set SOC return difference.	
Battery range below normal range.		

---



---

<b>Codes:</b>	05	<b>Solutions:</b>
<b>Content:</b>	Bat Over Vol	
<b>Explanation:</b>	Measure whether the battery voltage is within the battery voltage range allowed by the inverter.	
The battery voltage is higher than the voltage uploaded by the battery BMS to the inverter.		

---



---

<b>Codes:</b>	06 / 07	<b>Solutions:</b>
<b>Content:</b>	Gird low vol / over vol	
<b>Explanation:</b>	Check whether the local power grid name is selected.	
The mains voltage is lower than the local grid safety minimum./The mains voltage is higher than the maximum value specified by the local power grid.		

---

---

<b>Codes:</b>	08 / 09	<b>Solutions:</b>
<b>Content:</b>	Gird lowFreq / overFreq	
<b>Explanation:</b>	<p>The mains frequency is lower than the local grid safety minimum./The mains frequency is higher than the maximum value specified by the local power grid safety regulation.</p>	
		<p>Check whether the local power grid name is selected.</p>

---

<b>Codes:</b>	10	<b>Solutions:</b>
<b>Content:</b>	Gfci over	
<b>Explanation:</b>	<p>Machine leakage.</p>	
		<p>Check the wires for damage</p>

---

<b>Codes:</b>	11	<b>Solutions:</b>
<b>Content:</b>	Parallel CAN communication failure	
<b>Explanation:</b>	<p>/</p>	
		<p>This option is reserved.</p>

---

<b>Codes:</b>	13	<b>Solutions:</b>
<b>Content:</b>	Bus under vol	
<b>Explanation:</b>	<p>The internal bus voltage is low.</p>	
		<p>The system is powered off and restarts (disconnect PV, battery, and mains, wait until the machine screen is off, and then power on again).</p>

---

---

<b>Codes:</b>	14	<b>Solutions:</b>
<b>Content:</b>	Bus over vol	
<b>Explanation:</b>	High bus voltage inside the machine.	Check whether the PV input voltage is too high.

---

---

<b>Codes:</b>	15	<b>Solutions:</b>
<b>Content:</b>	Inv over cur	
<b>Explanation:</b>	The inverter current exceeds the normal value.	Check whether the load power is too large or there is a large power motor load.

---

---

<b>Codes:</b>	16	<b>Solutions:</b>
<b>Content:</b>	Chg over cur	
<b>Explanation:</b>	The charging current is set to exceed the current uploaded by the BMS to the inverter.	Check whether the set current exceeds the rated charging current allowed by the battery.

---

---

<b>Codes:</b>	17	<b>Solutions:</b>
<b>Content:</b>	MeterCommFail	
<b>Explanation:</b>	Meter communication is not connected to the specified position of the inverter.	Check whether the cable to the meter is normal and connected to the specified position of the inverter.

---

---

<b>Codes:</b>	18 / 19	<b>Solutions:</b>
<b>Content:</b>	Inv under vol / over vol	
<b>Explanation:</b>	The output voltage of the inverter is lower/higher than the operating voltage of the device.	The system is powered off and restarts (disconnect PV, battery, and mains, wait until the machine screen is off, and then power on again).

---

---

<b>Codes:</b>	20	<b>Solutions:</b>
<b>Content:</b>	InvFreqAbnor	
<b>Explanation:</b>	The output frequency of the inverter is higher or lower than the operating frequency of the device.	The system is powered off and restarts (disconnect PV, battery, and mains, wait until the machine screen is off, and then power on again).

---

---

<b>Codes:</b>	21	<b>Solutions:</b>
<b>Content:</b>	Igbt temp high	
<b>Explanation:</b>	The internal temperature of the inverter is too high.	Wait 30 minutes for the inverter to cool down and then power on.

---

---

<b>Codes:</b>	22	<b>Solutions:</b>
<b>Content:</b>	Bat BMS failure	
<b>Explanation:</b>	The battery BMS is faulty. Procedure.	Contact Battery manufacturer.

---

---

<b>Codes:</b>	23	<b>Solutions:</b>
<b>Content:</b>	Bat over temp	
<b>Explanation:</b>		Power off the inverter and check the battery.
	High battery temperature.	

---

---

<b>Codes:</b>	24	<b>Solutions:</b>
<b>Content:</b>	Bat UnderTemp	
<b>Explanation:</b>		Power off the inverter and check the battery.
	The battery temperature is too low. Procedure.	

---

---

<b>Codes:</b>	25	<b>Solutions:</b>
<b>Content:</b>	Bat Cell Unball	
<b>Explanation:</b>		Power off the inverter and check the battery.
	Battery voltages vary greatly.	

---

---

<b>Codes:</b>	26	<b>Solutions:</b>
<b>Content:</b>	Bat Reverse	
<b>Explanation:</b>		Check whether the battery cable sequence is reversed.
	The positive and negative battery terminals are connected in reverse.	

---

---

<b>Codes:</b>	27	<b>Solutions:</b>
<b>Content:</b>	BMS comm.fail	
<b>Explanation:</b>		Check whether the BMS communication network cable of the inverter is correctly connected.
	The inverter failed to communicate with the lithium battery BMS.	

---



---

<b>Codes:</b>	28	<b>Solutions:</b>
<b>Content:</b>	Battery failure	
<b>Explanation:</b>	Internal battery fault.	System power failure Check the battery.

---

---

<b>Codes:</b>	35	<b>Solutions:</b>
<b>Content:</b>	Inv short	
<b>Explanation:</b>	Ac short circuit.	Check whether the AC cable is short-circuited.

---

---

<b>Codes:</b>	37	<b>Solutions:</b>
<b>Content:</b>	PV iso low	
<b>Explanation:</b>	PV has low ground impedance.	Check whether the PV cable is damaged and grounded properly.

---

---

<b>Codes:</b>	38	<b>Solutions:</b>
<b>Content:</b>	Bus Relay Fault	
<b>Explanation:</b>	The soft-start relay on the power grid is faulty.	The system is powered off and restarts (disconnect PV, battery, and mains, wait until the machine screen is off, and then power on again).

---

---

<b>Codes:</b>	39	<b>Solutions:</b>
<b>Content:</b>	Grid Relay Fault	
<b>Explanation:</b>	Relay short circuit.	The system is powered off and restarts (disconnect PV, battery, and mains, wait until the machine screen is off, and then power on again).

---

---

<b>Codes:</b>	41	<b>Solutions:</b>
<b>Content:</b>	Gfci fault	
<b>Explanation:</b>	Abnormal leakage current.	The system is powered off and restarts (disconnect PV, battery, and mains, wait until the machine screen is off, and then power on again).

---

---

<b>Codes:</b>	42	<b>Solutions:</b>
<b>Content:</b>	Load CT fault	
<b>Explanation:</b>	Internal CT fault.	The system is powered off and restarts (disconnect PV, battery, and mains, wait until the machine screen is off, and then power on again).

---



## HEAD OFFICE

SALUS Controls  
Units 8-10, Northfield Business  
Park, Forge Way,  
Parkgate, Rotherham,  
S60 1SD, United Kingdom

SALUS Controls GmbH,  
Dieselstrasse 34,  
63165 Mühlheim am Main,  
Germany

---

Email: [sales@salus-tech.com](mailto:sales@salus-tech.com)



[www.saluscontrols.com](http://www.saluscontrols.com)

SALUS Controls is a member of the Computime Group

Maintaining a policy of continuous product development SALUS Controls plc reserves the right to change specifications, design and materials of products listed in this brochure without prior notice.

V01

10/2024

