



Manual

PRODUCER:
SALUS Controls Plc Units 8-10 Northfield
Business Park Forge Way, Parkgate,
Rotherham S60 1SD, United Kingdom



www.saluscontrols.com

SALUS Controls is a member of the Computime Group
Maintaining a policy of continuous product development. SALUS Controls plc
reserve the right to change specification, design and materials of products listed
in this brochure without prior notice.

Introduction

ERT20RF is an wireless, electronic and surface-mounted room thermostat that allows easily adjust the room temperature. It activates the heating system thru receiver contacts and informs about it with the red LED diode on the transmitter. Before the first run, please read manual instruction carefully. Thermostat should be powered with AA 1.5V alkaline batteries. The use of rechargeable batteries is prohibited.

Product Compliance

This product complies with the essential requirements and other relevant provisions of the following EU Directives:
2014/30/EU, 2014/35/EU, 2011/65/EU
(9) 868.0 MHz - 868.6 MHz; <13dBm
The full text of the EU Declaration of Conformity is available at the following internet address: www.saluslegal.com.



Safety Information

Use in accordance to national and EU regulations. Use the device as intended, keeping it in dry condition. Product for indoor use only. Installation must be carried out by a qualified person in accordance to national and EU regulations.

Technical Data

Transmitter power supply	2x AA alkaline batteries
Receiver power supply	230 V AC 50 Hz
Receiver max load	16 (5) A
Receiver output	Volt-free NO/COM relay
Setpoint temperature range	5 - 32.5°C
RF signal frequency	868 MHz

Proper thermostat placement

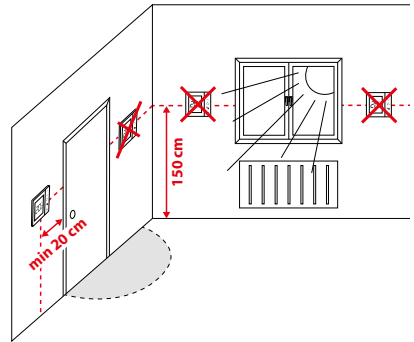

Principle of operation

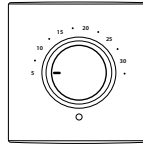

ERT20TX transmitter

Setpoint temperature of ERT20TX thermostat is set using a knob. To set the desired temperature, just set the dial to the desired value. If the heating mode is active, thermostat's LED diode will turn red.

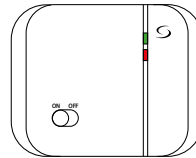

RXRT505 receiver

On the front of the receiver's housing there is an ON/OFF switch and two indication diodes.

Green diode lights up, when the receiver receives a signal from a transmitter with a heat demand.

Red diode lights up, when receiver is connected to the 230V AC power supply and the switch is in ON position.

RXRT505 Receiver terminals description

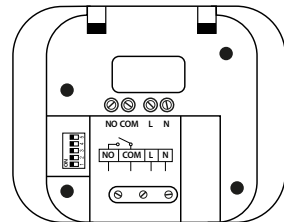

Terminal	Function
NO	Normal-open contact
COM	Common contact
L, N	230 V AC power supply

Wiring diagram

NOTE: Always isolate the AC Mains supply before installing or working on any components that require 230 V AC 50Hz supply. The assembly should be carried out by a person having appropriate electric permissions. Incorrect wires connection can damage the device.

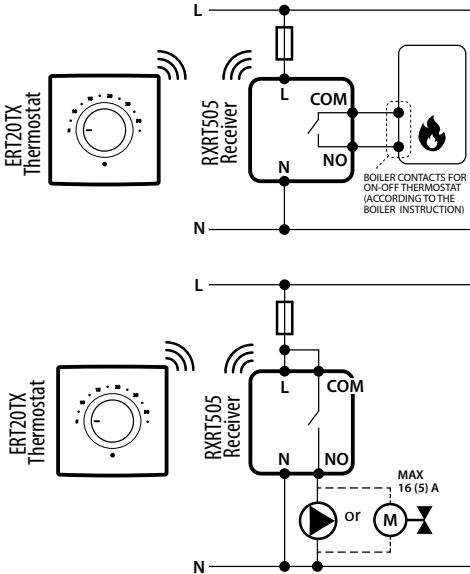

COMMUNICATION CODE CHANGE

NOTE: To avoid interference caused by other wireless devices, it is strongly recommended to change the communication code for other than factory.

- Communication code change is done by DIP switches (numbered 1-5). Set the DIP switches on the receiver in random positions.

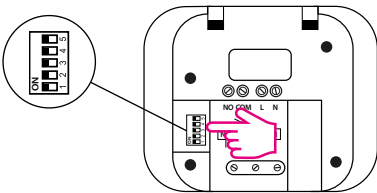

- Set the receiver's switch to the ON position - red LED diode on the receiver will start to flash.

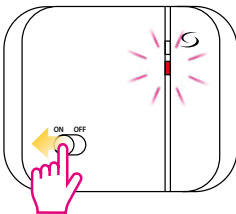

- Press and hold for 3 seconds SYNC button located on the back of the thermostat. Thermostat's red LED diode will start flashing.

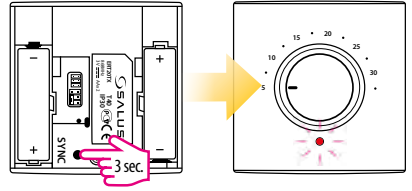

- If the LED diode on the receiver stops flashing, it means that the pairing process was successful.

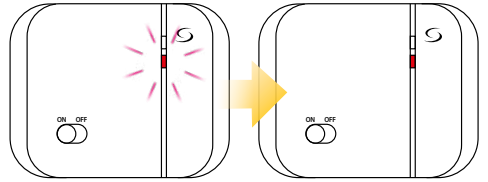

- To finish the pairing process, press and hold SYNC button again. LED diode on the thermostat will stop flashing.

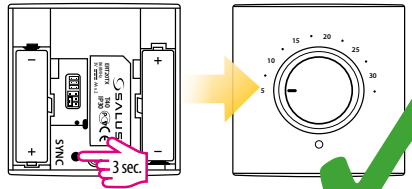

- To check if the devices have been paired correctly, set the thermostat knob to the maximum. Red led diode will light up on the thermostat and heating signal will be sent. If the green LED lights up on the receiver it means that the devices are paired correctly.

Heating/cooling mode changing

The ERT20RF thermostat is factory-adjusted to work with a heating device (heating mode), however, there is a possibility to switch it to cooling mode, so it can work also with a cooling device.

To change heating/cooling mode, change the position of the jumper on the back of the thermostat, as shown in the figure below:



Heating mode



Cooling mode

