

RT520RF

Boiler Plus Compliant Thermostat



The RT520RF is the latest addition to SALUS' tried and tested RT range of thermostat heating controls. With a new on-board load compensation feature, it offers the most cost effective fully compliant Boiler Plus solution on the market providing the homeowner with optimum efficiency and maximum heating control comfort.

The wireless RT520RF thermostat includes all the features of the previous RT series with a larger more intuitive LCD display and a handy new suite of additional operational and efficiency functions.

Characteristics

- Boiler Plus Compliant
- OpenTherm
- Landlord PIN
- Easy to Install
- 5 Year Warranty
- Big LCD screen
- Advanced functions
- Easy to use

Features

Product	Boiler Plus Compliant Thermostat
Power supply	2 x AA Alkaline batteries
Control:	OpenTherm or Voltage free output-COM/NO
Scale	5 - 32.5°C
Measuring :	0.1°C or 0.5°C
Control algorithm:	TPI (Time Proportional & Integral): $\pm 0.25^{\circ}\text{C}$ or $\pm 0.5^{\circ}\text{C}$
Communication	Wireless, 868 Mhz
RF Frequency	868Mhz (up to 30m range)
Dimensions (mm)	
Regulator :	118 x 95 x 26
Receiver :	96 x 96 x 27

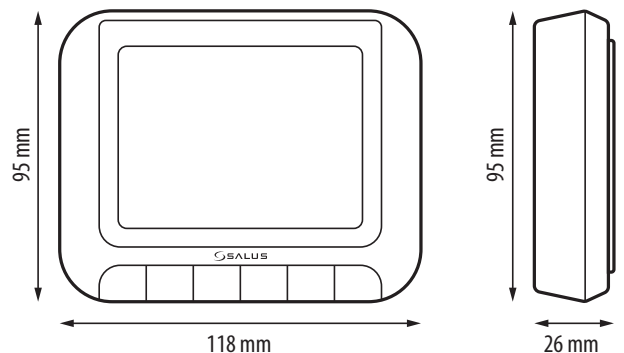

Connection scheme

