



(8 ZONES) - 230V AC

**KL08RF
ZIGBEE NETWORK
WIRELESS WIRING CENTRE
QUICK GUIDE**



Manufacturer:
SALUS Controls plc
Units 8-10,
Northfield Business Park,
Forge Way, Parkgate
Rotherham, S60 1SD, UK

Importer:
Salus Controls European
Distribution sp.z o.o. ul.
Szamocka 8, piętro 6.
01 748 Warszawa
Poland

UK: tech@salus-tech.com
DE / NL: info@salus-controls.de
PL: poland@saluscontrols.com
FR: technicalsupport@saluscontrols.fr
RO: tehnic@saluscontrols.ro
DK: Support@salus-controls.dk



www.saluscontrols.com

SALUS Controls is a member of the Computime Group
Maintaining a policy of continuous product development SALUS
Controls plc reserves the right to change specifications, design
and materials of products listed in this brochure without prior notice.



01/2026

KL08RF (WIRING CENTRE DESCRIPTION)

- | | | |
|---------------------------------|-------------------------------------|---|
| 1. Cartridge fuse 5 x 20 mm 12A | 7. Delay jumper | 13. Boiler control output (volt free) |
| 2. Power Supply | 8. INT/EXT antenna jumper | 14. CO terminal |
| 3. Thermostat grouping status | 9. NC/NO actuators jumper | 15. Dew point sensor input (humidity) |
| 4. Network Status LED | 10. ZigBee network coordinator | 16. Serial connector for the KL04RF extension |
| 5. Pair button | 11. Terminals for actuators (230V) | 17. External antenna connector |
| 6. Reset button | 12. Pump control output (volt free) | |

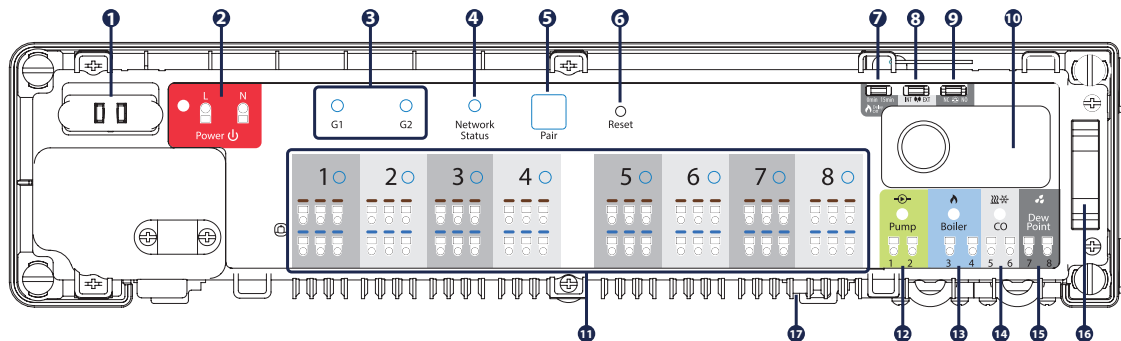

RX10RF & RX30RF Boiler Receiver (optional)

Additional, wireless device control module that can be used - for example- when we can't use cable between the KL08RF wiring centre and the boiler.

C010RF (ZIGBEE NETWORK COORDINATOR)



The ZigBee network coordination unit C010RF is used for Offline mode and it's included with the wiring centre. C010RF enables wireless control of all devices installed in one network. Within one network can be connected max 9 wiring centres. It means that if in the network there are more than one wiring centre, you can use one coordinator and put the remaining ones in a safe place.

NOTE: Do not use C010RF coordinator with UG600/UG800 simultaneously.



C010RF Operation

Normal operation		LED - solid red
Identification mode		Short press again to stop identification. Identification active. LED is flashing green.
Device pairing		Network is open for pairing to begin LED flashing red
Factory reset		This command resets the network. After performing the factory reset, all devices must be paired again.

Introduction

The KL08RF wireless wiring centre is a part of the iT600 system. In combination with the wireless thermostats from iT600 series, KL08RF provides comfortable and reliable heating control. It is equipped with the control outputs for the pump and boiler and has been designed to work with NC or NO actuators.

In Offline mode, communication with the wireless thermostats from iT600 series must be done through the C010RF coordinating unit, which is in the package together with the wiring centre.

To work in Online mode (via the SALUS Premium Lite app) KL08RF must be connected to the Internet gateway UG600/UG800. In one ZigBee network (Online or Offline) up to nine KL08RF wiring centres can be connected. KL08RF increases ZigBee network range.

Product Compliance

This product complies with the essential requirements and other relevant provisions of Directives GPRS 2023/988/EU, EMC 2024/2749/EU, LVD 2014/35/EU, RED 2025/138/EU and RoHS 2017/2102/EU. The full text of the EU Declaration of Conformity is available at the following internet address: www.saluslegal.com.
(P) 2405-2480MHz, <14dBm

Safety Information

Use in accordance to national and EU regulations. Use the device as intended, keeping it in dry condition. Product for indoor use only. Installation must be carried out by a qualified person in accordance to national and EU regulations.

Technical Information

Power	230V AC 50 Hz
Max load	5 A
Inputs	CO terminal Dew point sensor (humidity)
Outputs	Pump control Boiler control Terminals for actuators (3A max per relay)
Radio frequency	ZigBee 2,4 GHz
Dimensions (mm)	355 x 83 x 67

1. FUSE

NOTE: Fuse replacement should be done when the wiring centre is disconnected from power supply 230V AC.D

The mains fuse is located under the housing cover, at the main terminals and protects the wiring centre and devices powered by it. Use cartridge fuse-type 5 x 20 mm - nominal burn rate 12 A. To remove the fuse, lift the socket with a flat screwdriver and pull out the fuse.

2. POWER SUPPLY

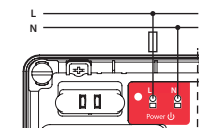

Power supply for wiring centre is 230V ~, 50Hz.

Must be installed with regards to current electrical regulations for your region.

3. THERMOSTAT GROUPING STATUS

This function is only available in Offline mode (together with C010RF coordinator) - it means MASTER thermostats will affect to SLAVE thermostats within specific group, which is possible only when thermostats are paired with one KL08RF wiring centre (optional + KL04RF) and have been assigned to gr. 1 or gr. 2.

NOTE: Within one group there may be only one MASTER thermostat (programmable) and the res must be SLAVE thermostats (non-programmable).

How it works: If all thermostats of a given group will operate in automatic mode, then each of the thermostats in a given group will work in the same way as the MASTER of this group. For example, if the MASTER thermostat of Group 1 according to it's programmed schedule maintains a comfort mode - all SLAVE types thermostats from Group 1 will also maintain the comfort mode (the temperature is set individually for every thermostat). Similarly, if the MASTER thermostat is set to Party or Holiday mode - SLAVE thermostats in his group will also work in these modes.

The grouping function is optional - thermostats can operate independently.

4. NETWORK STATUS LED

LED is blinking green - it means wiring centre is not yet connected to the network, but it is ready for pairing with the coordinator of the ZigBee network (C010RF) or the Internet gateway (UG600)

LED has a "double flash" green pattern (repeating) - it means wiring centre has left the network but it's not in pairing mode. Short press on the reset button to put it back in pairing mode.

LED is steady lit green - it means wiring centre is added to the ZigBee network and paired with C010RF or UG600/UGE600

5. PAIR BUTTON

Functions of the Pair button:

 Checking the address of the wiring centre in the ZigBee network. To check the address of the wiring centre in the ZigBee network (when using more than one) press the Pair button.

The wiring centre number is indicated by the lighting of a single green LED on a certain zone (see below).

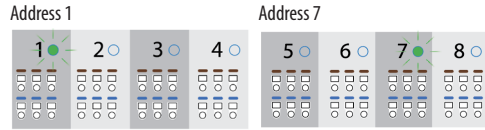



 **NOTE:** Address 9 is indicated by lighting the 8 LED zone and the Network Status LED in green colour.

 Factory reset the wiring centre (this function is described in detail at the end of the quick guide).

6. RESET BUTTON

 It is used to refresh the data, after moving jumpers 7,8 or 9. The Reset button does not remove the wiring centre from the ZigBee network.

7. DELAY JUMPER

 Boiler off delay time.  Jumper position change must be refreshed in the memory by pressing the Reset button (short press).

 **NOTE:** Pump (Pump output) and boiler (Boiler output) always starts 3 minutes after receiving the heating signal from any thermostats paired with wiring centre. Pump stops after 3 minutes, when the last thermostat stops sending demand for heat, while the heat source (Boiler) will turn off after the time set with the jumper.

8. INT/EXT ANTENNA JUMPER

 There is an option to connect the 08RFA external antenna to the wiring centre. If you use an additional antenna, place the jumper in the EXT position.

 **NOTE:** Jumper position change must be refreshed in the memory by pressing the Reset button (short press).

9. NC/NO ACTUATORS JUMPER

 Select the type of the thermoelectric actuator connected to the wiring centre:

NC - actuator normally closed
NO - actuator normally opened

 **NOTE:** Jumper position change must be refreshed in the memory by pressing the Reset button (short press).

10. TERMINALS FOR ACTUATORS

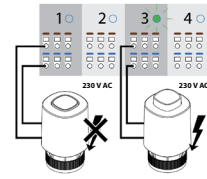

The operation was explained on the example of T30NC actuators (zone 3 blinking green).

Wires of the thermoelectric actuators should be plugged into the self-locking connectors in the appropriate zones. You can connect 3 actuators directly to one zone. The current load of one zone is adapted to operate with up to 6 thermoelectric actuators with a power of 2 Watts. If there is a need to connect more than 6 actuators please use an additional relay to relieve the output of the zone.

11. PUMP CONTROL OUTPUT

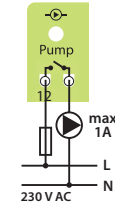

Pump output - this is a volt free output (COM / NO) that controls the circulation pump in the heating / cooling system. The output closes (pump starts) always after 3 minutes after receiving the heating / cooling signal from any of thermostats paired with wiring centre. The output opens (pump stops) after 3 minutes, when the last thermostat stops sending heat / cold demand.

12. BOILER CONTROL OUTPUT

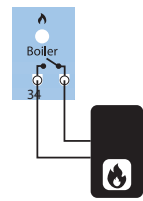





Boiler output - this is a volt free output (COM / NO) that controls the boiler in the heating system. The output closes and the boiler turns on but always after 3 minutes after receiving the heating signal from any of thermostats paired with wiring centre. The output opens and the boiler switches off when the last thermostat stops sending heat demand (after the time set on the Delay jumper).

 Boiler output is inactive in cooling mode.

13. CO TERMINAL (INPUT)

Opened CO input contacts (Changeover) means that whole system works in the heating mode. Short circuit at the input CO will automatically switch the whole system to cooling mode (wiring centre and paired thermostats).

CO terminal	Diode	Mode
Open contacts	 Red	 Heating
Closed contacts	 Blue	 Cooling

14. DEW POINT SENSOR INPUT (HUMIDITY)

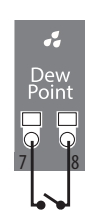

 Dew point sensor input is active only in cooling mode (with closed CO contacts).

Shorting the contacts at the dew point sensor input (too high humidity) causes switching off all zones in the wiring centre and Pump control outputs.

15. SERIAL CONNECTOR FOR THE KLO4RF EXTENSION

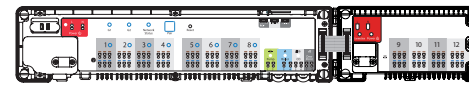







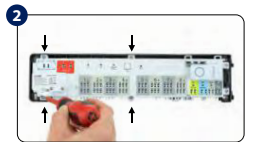

It is used for communication between the KLO8RF wiring centre and the KLO4RF extension module. KLO4RF extension module increases functionality and expands support up to 12 zones.

16. EXTERNAL ANTENNA CONNECTOR

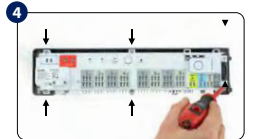
The external antenna connector 08RFA is located underneath the wiring centre under zones 7 and 8. After connecting an additional antenna, place the jumper in the EXT position.

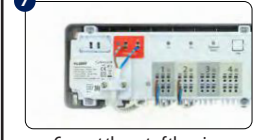
 Jumper position change must be refreshed in the memory by pressing the Reset button (short press).

WIRING & MOUNTING

-  Remove the top cover.
-  For wall mounting, unscrew the main part of the housing (see picture). To mount on the DIN rail, tilt the hooks on the back of the housing.
-  Attach the back plate to the wall. You can also mount KLO8 on a DIN rail.
-  Screw the main part of the wiring centre to the back plate.
-  Remove the appropriate section of insulation from the wires.
-  Connect the power cord.
-  Connect the rest of the wires.
-  Remove the CO10RF coordinator if you use the UG600/ UG800 gateway.
-  Make sure that all the wires are properly connected then connect the power cord to the 230 V AC power supply - red LED diode will light up.
-  After finishing installation mount the top cover of wiring centre.

INSTALLATION

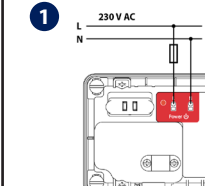
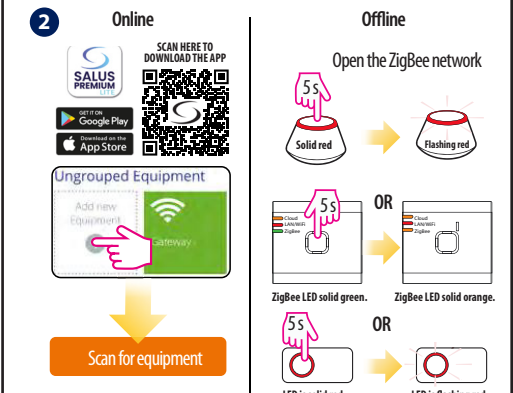
-  Connect the wiring centre to the 230 V AC power supply. The Network Status LED will blink.
- 

Online

SCAN HERE TO DOWNLOAD THE APP

Get it on Google Play

Download on the App Store

Ungrouped Equipment

Add new Equipment

Scan for equipment

Offline

Open the ZigBee network

5s

Solid red → Flashing red

ZigBee LED solid green. OR ZigBee LED solid orange.

5s

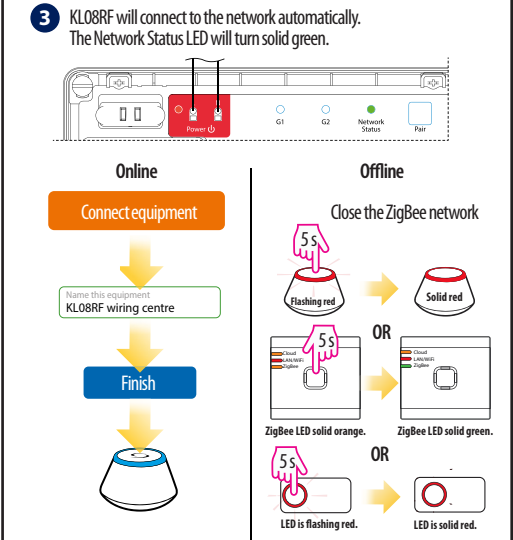
LED is solid red. OR LED is flashing red.
- 

KLO8RF will connect to the network automatically. The Network Status LED will turn solid green.

Online

Connect equipment

Name this equipment

KLO8RF wiring centre

Finish

Offline

Close the ZigBee network

5s

Flashing red → Solid red

ZigBee LED solid orange. OR ZigBee LED solid green.

5s

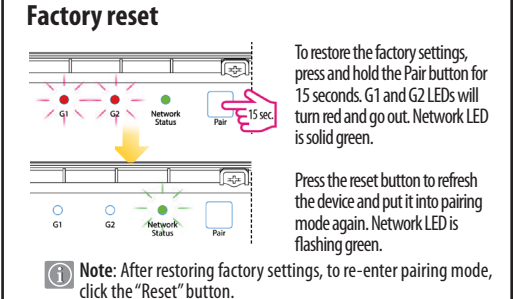
LED is flashing red. OR LED is solid red.
- 

Factory reset

To restore the factory settings, press and hold the Pair button for 15 seconds. G1 and G2 LEDs will turn red and go out. Network LED is solid green.

Press the reset button to refresh the device and put it into pairing mode again. Network LED is flashing green.

 **Note:** After restoring factory settings, to re-enter pairing mode, click the "Reset" button.